SECURITIES AND EXCHANGE COMMISSION
Washington, D. C. 20549

FORM 10-K

Annual report pursuant to Section 13 or 15(d) of the Securities Exchange Act of 1934
For the fiscal year ended December 31, 2008

Transition report pursuant to Section 13 or 15(d) of the Securities Exchange Act of 1934
001-9731
(Commission file number)

ARRHYTHMIA RESEARCH TECHNOLOGY, INC.

(Name of registrant as specified in its charter)

Delaware (State or other jurisdiction of incorporation of organization)	72-0925679 (IRS Employer Identification Number)
25 Sawyer Passway, Fitchburg, MA (Address of principal executive offices)	01420 (Zip Code)
(978) 345-5000 (Registrant's telephone number)	

Securities Registered pursuant to Section 12 (b) of the Act:

Common Stock, \$.01 par value (Title of Each Class)	NYSE AMEX (Name of each exchange on which registered)
---	---

Securities Registered Pursuant to Section 12 (g) of the Act:
None

Indicate by check mark if the registrant is a well-known seasoned issuer, as defined in Rule 405 of the Securities Act.
Yes No

Indicate by check mark if the registrant is not required to file reports pursuant to Section 13 or 15(d) of the Exchange Act. Yes No

Indicate by check mark whether the registrant (1) filed all reports required to be filed by Section 13 or 15(d) of the Securities Exchange Act of 1934 during the preceding 12 months (or for such shorter period that the registrant was required to file such reports), and (2) has been subject to such filing requirements for the past 90 days. Yes No

Indicate by check mark if disclosure of delinquent filers in response to Item 405 of Regulation S-K is not contained herein, and will not be contained, to the best of registrant's knowledge, in definitive proxy or information statements incorporated by reference in Part III of this Form 10-K or any amendment to this Form 10-K.

Indicate by check mark whether the registrant is a large accelerated filer, an accelerated filer, a non-accelerated filer, or a smaller reporting company. See the definitions of "large accelerated filer," "accelerated filer" and "smaller reporting company" in Rule 12b-2 of the Exchange Act. (Check one):

Large Accelerated filer Accelerated filer Non-Accelerated filer Smaller reporting company

Indicate by check mark whether the registrant is a shell company (as defined in Rule 12b-2 of the Exchange Act).
Yes No

State the aggregate market value of the voting and non-voting common equity held by non-affiliates computed by reference to the price at which the common equity was last sold, or the average bid and asked price of such common equity, as of the last business day of the registrant's most recently completed second fiscal quarter. \$14,254,890.

On March 21, 2009 there were 2,688,291 shares of the issuer's common stock, par value \$.01, outstanding, which is the only class of common or voting stock of the issuer.

DOCUMENTS INCORPORATED BY REFERENCE

The registrant intends to file a definitive proxy statement pursuant to Regulation 14A within 120 days of the end of the fiscal year ended December 31, 2008. Portions of such proxy statement are incorporated by reference into Part III of this Form 10-K.

Arrhythmia Research Technology, Inc.

TABLE OF CONTENTS

Part I	Item 1	Business	1
	Item 1A	Risk Factors	8
	Item 2	Properties	10
	Item 3	Legal Proceedings	10
	Item 4	Submission of Matters to a Vote of Security Holders	10
Part II	Item 5	Market for Registrant’s Common Equity, Related Stockholder Matters and Issuer Purchases of Equity Securities	11
	Item 6	Selected Financial Information	12
	Item 7	Management’s Discussion and Analysis of Financial Condition and Results of Operation	12
	Item 7A	Quantitative and Qualitative Disclosures about Market Risk	18
	Item 8	Consolidated Financial Statements and Supplementary Data	18
	Item 9	Changes in and Disagreements with Accountants on Accounting and Financial Disclosures	18
	Item 9A	Controls and Procedures	18
	Item 9B	Other Information	19
Part III	Item 10	Directors, Executive Officers, and Corporate Governance	19
	Item 11	Executive Compensation	19
	Item 12	Security Ownership of Certain Beneficial Owners and Management and Related Stockholder Matters	19
	Item 13	Certain Relationships and Related Transactions, and Director Independence	20
	Item 14	Principal Accountant Fees and Services	20
Part IV	Item 15	Exhibits and Financial Statement Schedules	20
		Signatures	21

PART I

Item 1. BUSINESS.

OVERVIEW

Arrhythmia Research Technology, Inc., a Delaware corporation ("ART"), is engaged in the development of medical software, which acquires data and analyzes electrical impulses of the heart to detect and aid in the treatment of potentially lethal arrhythmias. ART's patented products consist of signal-averaging electrocardiographic (SAECG) software whose proprietary Windows based version is named the Predictor[®] series. Rather than having a direct sales force, our current intent is to market ART's product through licensing with original equipment manufacturers. There were no sales or licensing of the software in 2008 or 2007.

Our SAECG product is currently used in a National Institutes for Health ("NIH") funded investigation into "Risk Stratification in MADIT II Type Patients". At the completion of this study and assuming favorable study results, we will seek to establish licensing contracts with original equipment manufacturers for this product.

Sudden cardiac death afflicts over 300,000 individuals in the United States each year. Most sudden cardiac deaths are due to sustained ventricular tachycardia (abnormally rapid heartbeat) or ventricular fibrillation (very fast, completely irregular heartbeat). Ventricular Late Potentials may indicate a risk of life-threatening ventricular arrhythmias. The SAECG processes enable Late Potentials to be amplified and enhanced, while eliminating undesired electrical noise.

ART's wholly owned subsidiary, Micron Products, Inc., a Massachusetts corporation ("Micron"), is a manufacturer and distributor of silver plated and non-silver plated conductive resin sensors ("sensors") used in the manufacture of disposable integrated electrodes constituting a part of electrocardiographic diagnostic and monitoring instruments. Micron also acts as a distributor of metal snap fasteners ("snaps"), another component used in the manufacture of disposable electrodes. The sensors are a critical component of the signal pathway in many different types of disposable electrodes. For example, the disposable electrodes used to capture the electric impulses of the heart and enable the analysis of Late Potentials require sensors which provide for an accurate, low noise signal to be transmitted to the monitoring device. Micron also manufactures and sells or leases assembly machines to its sensor and snap customers.

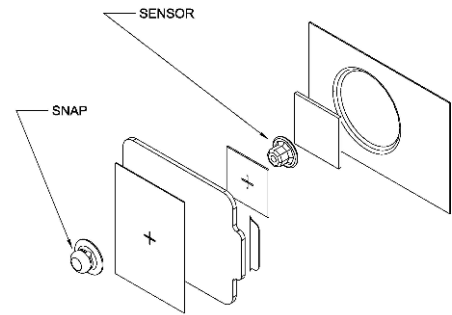

Figure 1: Schematic of Integrated ECG Electrode.

Micron is one of a few companies providing silver / silver-chloride sensors to the medical device industry. Micron's customers manufacture monitoring and transmitting electrodes which are utilized in a variety of bio-feedback and bio-stimulation applications including, among many others, electrocardiograms (ECG's), electroencephalograms (EEG's), electro-muscular stimulation (EMS), and thermo-electrical neural stimulation (TENS). Micron also produces high volume precision plastic products. These high volume products leverage the production skills for the resin sensors while providing a diversification from the dependence on a single product line.

In 2004, Micron completed the purchase of substantially all of the operating assets of privately held Shrewsbury Molders Inc. formerly known as New England Molders, Inc. of Shrewsbury, Massachusetts forming the New England Molders ("NEM") division of Micron. This division is a custom thermoplastic injection molder that produces a wide variety of consumable medical products, medical devices and equipment components, and other products for the consumer, electronic, aerospace, and defense industries. The NEM division is located along with Micron at the Company's Fitchburg complex in a renovated 100 year old brick mill building. The location provides operational synergies between Micron and NEM in manufacturing and administration. In early 2007, a class 10,000 level clean room was constructed for precision injection molding. This manufacturing space was fully operational in February 2007.

Micron Integrated Technologies (“MIT”), a division of Micron formed in January 2006, specializes in the production of metal and plastic components and assemblies for the medical and defense industries. Leveraging the high quality manufacturing of the NEM division’s plastic production capacity and Leominster Tool Division’s production capabilities with a comprehensive portfolio of value-added manufacturing, design and engineering services, the division provides complete product life cycle management: from concept to product development, prototyping, volume production, and assembly. The success of the division, which is located in the Fitchburg complex, is dependent on a comprehensive network of small, highly specialized manufacturing partners to produce a wide variety of component parts for the manufacture of the division’s products.

The Leominster Tool Division (“LTD”), which was formed following the December 2006 purchase of substantially all of the operating assets of privately held Leominster Tool Company, Inc., with a customer base in die casting, and thermoplastic injection molding also vertically integrates the design, manufacture, and repair of production injection molding tooling used by Micron, NEM, and MIT. Micron and its divisions benefit from an in-house source for injection molding tooling as well as new capabilities in the production of metal components. In 2008, LTD was fully integrated into the Fitchburg complex.

PRODUCTS

The following table sets forth for the periods specified, the revenue derived from the products of ART and its subsidiary Micron (collectively the "Company"):

	Year Ended December 31,			
	2008	%	2007	%
Sensors	\$ 9,398,287	42	\$ 9,510,871	49
Other molded products.....	2,574,301	11	3,161,497	16
Snaps and snap machines.....	203,562	1	130,385	1
Subassembly and metal component manufacturing ...	7,384,790	33	5,129,586	26
Injection molding tooling.....	1,478,970	7	1,094,281	6
Custom manufactured metal medical devices.....	1,186,435	5	234,843	1
Other products	255,874	1	226,299	1
Total.....	\$ 22,482,219	100	\$ 19,487,762	100

Sensors

Micron is a manufacturer and distributor of silver-plated and non-silver plated conductive resin sensors for use in the manufacture of disposable electrodes for ECG diagnostic, monitoring and related instrumentation. The type of sensor manufactured by Micron consists of a molded plastic substrate plated with a silver / silver chloride surface, which is a highly sensitive conductor of electrical signals. Silver / silver chloride-plated disposable electrodes are utilized in coronary care units, telemetry units, and for other monitoring purposes. In addition to the traditional ECG tests, disposable electrodes incorporating Micron’s sensor are used in connection with stress tests, Holter monitoring, and event recorders.

Micron also manufactures sensors and conductive plastic studs used in the manufacture of radio translucent electrodes. The radio translucent conductive plastic studs are manufactured with uniquely engineered resin to enable electrical conductivity between the sensor and the recording instrument without the use of a metal snap. The radio translucent electrodes are virtually invisible to X-rays and are preferred in some medical environments such as nuclear medicine, cardiac catheterization laboratories, and certain stress procedures. Micron also manufactures the mating conductive resin snaps, which replace traditional metal snap fasteners in the radio translucent applications.

Other custom designed sensors are manufactured for specific unique applications in the EEG, EMG or TENS markets. Recent growth in the volume of highly engineered EEG sensors reflects the increasing demand for noninvasive measuring of neurological impulses. Micron’s strength in design and low cost manufacturing support enables our customers to grow into unique niche medical applications and electrophysiological monitoring with custom designed sensors.

Other Molded Products

Micron also sells high volume precision custom molded component parts. The Company's sales in these high volume molded products diversify our existing product lines while utilizing previously unused manufacturing capacity. To defray the customer's upfront tooling costs and remain competitive with global competition, some high volume customers require the financing of a customer specific tool over several years. The cost of the tool is guaranteed by the customer and repaid over time as the molded product is shipped.

The inclusion of the NEM division in the Micron molding facility increased production flexibility, and dramatically expanded the capability to produce an increased size and complexity of products. From consumable medical products to medical equipment components, this division has decreased Micron's dependence on sensor production for manufacturing growth. In order to leverage the NEM division's thermoplastic injection molding capabilities, the MIT division produces assemblies using plastic molded components produced by NEM and assembled with outsourced and internally produced metal components.

Snaps and Snap Machines

Metal Snap Fasteners

Metal snap fasteners are used as an attachment and conductive connection between the disposable electrode and the lead wires of an ECG machine. Micron purchases the metal snap fasteners for resale from multiple suppliers and performs additional quality assurance tests, repackages and stocks these snap fasteners for its customers who purchase the snaps in addition to Micron's sensors.

High Speed Electrode Assembly Machine

Certain manufacturers of disposable medical electrodes use the Company's attaching machines in the assembly of sensors and snaps into disposable electrodes. Manufacturing, leasing, selling, and providing replacement parts to medical sensor and snap application machines provide Micron with a complimentary product to sell to existing sensor and snap customers. As a value added service, a technician can be dispatched to troubleshoot and improve the performance of our customers' fully automated electrode assembly production lines.

Other Products and Services

Subassembly and metal component manufacturing

The MIT division's product life cycle management program is focused on the integration of plastic and metal components into subassemblies. The value added service of in house production capabilities combined with a network of subcontracted specialty coatings, metallurgical treatments, and unique production abilities has diversified this product line to include defense industry consumables and equipment subassemblies for medical device components.

Injection Molding Tooling

The design, manufacture, and rehabilitation of injection molding tools for our customers are part of the service package provided by the NEM division. The design and manufacture of tooling is a leading indicator of future product revenue. The Company's engineering and mold designers work with customers' product development engineers to design and produce unique tooling for their products. Micron's expertise in cost effective manufacturing creates a sustainable partnership with our customers as prototyped parts move to full scale production.

The LTD's primary product is thermoplastic injection molding tooling. The division provides cost savings to Micron by vertically integrating mold making and repair into the structure of Micron's sensor and custom injection molding businesses, and provides in-house services for the NEM and MIT divisions. The division continues to generate revenues from other customers for similar industrial applications, metal die casting molds, investment casting wax molds, and thermoplastic injection/extrusion blow molds.

Custom Manufactured Metal Medical Devices

During 2007, a climate controlled medical machining cell was built for the custom computer aided design and computer controlled metal machining of patient specific orthopedic medical device components. The new manufacturing space includes a machine programming office with the latest technology in computer programming for 5-axis machining with CNC vertical milling machines and a state of the art 5-axis machining center. These products involve complex machining of wrought and cast cobalt-chromium-molybdenum alloy as well as high molecular weight polymers into unique customized products. No two components are identical and require precision manufacturing verified by complex computer controlled automated coordinate measuring equipment that measure up to 25 points per

square inch. The new space can accommodate a 50% increase in manufacturing capacity before any physical constraints are realized to this climate controlled space.

Signal-Averaging Electrocardiographic (SAECG) Products - Predictor® 7

The Predictor® 7 software is a Windows® compatible version of Arrhythmia Research Technology's analytical program for the detection of Late Potentials. Predictor® 7 utilizes the unique, patented Bi-directional, Four-Pole Butterworth Filtering technique defined as the "Standard" by the joint AHA/ACC/ESC task force on Signal-Averaging Electrocardiography¹. All clinically accepted measurement criteria are provided: total QRS duration, duration of the QRS under 40 µV, the RMS voltage of the last 40 msec of the QRS and the noise level. Graphical output of the analysis is presented both on screen and in hard copy. Predictor® 7 also incorporates additional signal processing capabilities for clinical research. The IntraSpect™ module permits detection of ventricular late potentials in patients with Bundle Branch Block. P-wave signal averaging helps predict patients at risk for atrial fibrillation and flutter. A Heart Rate Variability module can be incorporated on the Predictor platform.

The SAECG product is currently used in a National Institutes for Health ("NIH") funded investigation into "Risk Stratification in MADIT II Type Patients". The primary objectives of this study are: 1. To evaluate the predictive value of a multivariate model consisting of pre-specified clinical and ECG parameters for predicting arrhythmic events in Multicenter Automatic Defibrillator Implantation Trial II ("MADIT II") type post-infarction patients; 2. To develop a multivariate risk-stratification model, based on a broader spectrum of pre-specified clinical covariates and ECG parameters, and from it a risk-scoring algorithm identifying high-risk and low-risk patient groups; this algorithm will be validated by a cross-validation study. Such an algorithm will enable an ordering of patients who may benefit most, and benefit least, from implantable cardiac defibrillator ("ICD") therapy. At the completion of this study, estimated in 2010, and assuming favorable study results, we will seek to establish licensing contracts with original equipment manufacturers for this product.

GENERAL

Customers and Sales

During the year ended December 31, 2008, there were three major customers, each of which accounted for over 10% of the Company's sales and a loss of this base may have a material adverse effect on results. The three largest customers accounted for 27%, 17%, and 12% of sales in 2008 as compared to the two largest customers at 27% and 25% of sales for the year ended December 31, 2007.

Micron manufactures its sensors against purchase orders from electrode manufacturers. The Company is aware of approximately 20 significant manufacturers of disposable snap type, radio translucent and pre-wired electrodes worldwide. Micron sells its sensors to most of these manufacturers. Sales backlog is not material to Micron's sensor business due to the method of ordering employed by its customer base in this competitive industry. Customers generally purchase on a single purchase order basis without long-term commitments.

The majority of the NEM and MIT divisions' customers for injection molded thermoplastic products are from the medical equipment, medical device and defense industries. From single use medical or defense consumable products to equipment components, the engineered production services provide quality design and production capacity which exceed our customers' manufacturing requirements. Certain customers require that an inventory of their products be maintained at all times to enable just in time delivery schedules. A commitment from customers is required by NEM and MIT to maintain the higher level of finished goods inventory and raw material required for their products. These agreements allow for a more flexible manufacturing schedule with longer more cost effective production cycles. NEM's primary target customer is a medical manufacturer or development company with a need for complex custom injection molded components. MIT's primary target customer is a defense or medical manufacturer or development company with a need for complete product life cycle management from design to full production preferably combining multiple manufacturing technologies such as plastic injection molding, metalworking, assembly, and packaging.

Windows® is a registered trademark of Microsoft Corporation

¹ AHA/ACC/ESC Policy Statement: "Standards for the Analysis of Ventricular Late Potentials Using High Resolution or Signal-Averaged Electrocardiography: A Statement by a Task Force Committee of the European Society of Cardiology, the American Heart Association and the American College of Cardiology. JACC Vol. 17, No. 5, April 1991:999-1006

The following table sets forth, for the periods indicated, the approximate consolidated revenues and percentages of revenues derived from the sales of all of the Company's products in its geographic markets:

	Revenues for the Years Ended December 31,			
	2008	%	2007	%
United States	\$ 13,290,098	59	\$ 10,824,992	55
Canada.....	5,118,913	23	5,426,042	28
Europe.....	3,091,326	14	2,496,012	13
Pacific Rim.....	426,764	2	335,592	2
Other	555,118	2	405,124	2
Total.....	\$ 22,482,219	100	\$ 19,487,762	100

While some risks exist in foreign markets, the vast majority of the Company's customers are based in historically stable markets. To reduce the risks associated with foreign shipment and currency exchange fluctuations, the title to most of our products are transferred to our customers when shipped, and payment is required in U.S. Dollars.

To help offset the risk from fluctuations in the market price of silver, sensor customers have generally been subject to a silver surcharge or discount based on the market price of silver at the time of shipment. The Company is sensitive to the impact of recent increases in silver cost, and continues to explore options with our customers to help mitigate the resulting increases in surcharges.

Marketing and Competition

Micron sells its sensors to large, sophisticated OEM manufacturers of disposable snap type and radio translucent ECG electrodes who compete internationally in the electrode market against other OEM manufacturers as well as manufacturers of tab-type electrodes. The Company has one major domestic competitor in the sensor market along with an increasing number of minor competitors worldwide. The sensor and snap market is extremely price sensitive and barriers to entry are relatively low. The Company competes with respect to its sensor products on the basis of pricing, technical capabilities, quality of service and ability to meet customer requirements. With no import restrictions, the Company's foreign competitors with excess capacity can be expected to expand sales in the U.S. In addition, many of the major OEM customers, although not currently manufacturing silver-silver chloride sensors, have the ability to do so with modest investment.

The Company markets Micron and its NEM division as a highly specialized custom injection thermoplastic molder to new and existing customers. The Company believes it competes effectively based on its expertise in low cost manufacturing of high volume precision products. The complex medical products produced by the NEM division have expanded our existing customer base and extensively diversified the product mix. It is our intention to continue these efforts to market to the expanded customer base and further diversify our product offerings. Global competition creates a highly competitive environment. To meet this challenge, the NEM and MIT divisions focus their product development efforts on complex close tolerance products not readily outsourced to offshore manufacturing.

Management is currently pursuing licensing of the SAECG products to original equipment manufacturers for integration into existing cardio diagnostic equipment. As previously stated, the SAECG product is currently used in a National Institutes for Health ("NIH") funded investigation into "Risk Stratification in MADIT II Type Patients". At the completion of this study and assuming favorable study results, we intend to establish multiple licensing contracts with original equipment manufacturers for this product.

Product Suppliers and Manufacturing

Micron manufactures its sensors at its Fitchburg, Massachusetts facility employing a proprietary non-patented multi-step process. All employees sign confidentiality agreements to protect this proprietary process. The raw materials used by Micron are plastic resins used to mold the substrates and silver-silver chloride chemical solutions for plating the molded plastic substrates. Both the resins and the chemicals involved in the silver-silver chloride process are available in adequate supply from multiple commodity sources. As insulation against unanticipated price increases, some resins and chemicals used in the production of sensors are purchased in large quantities to lower or stabilize prices.

Resins used by the custom molding division are purchased for an individual customer order, with most increases in resin costs passed on to the customer as orders are acknowledged. Because the customer order determines the quantity of material required, customers may, and have, guaranteed the purchase of specific large quantities of

product which allows the division to purchase raw material at a more favorable cost thereby lowering the final cost to the customer. The metal alloys used by the MIT division in its products are subject to the same customer order limitations, and prices are fixed as the customer guarantees an order.

Micron distributes medical grade nickel-plated brass and stainless steel snap fasteners purchased from multiple domestic and international sources. Micron buys these snaps in bulk, performs additional quality assurance tests, and stocks inventory to facilitate just-in-time shipments to its customers. This business segment has decreased significantly in revenue as price pressure has forced metal snap customers to buy direct from the manufacturer to remain competitive.

The Company's 116,000 square foot manufacturing facilities are ISO 9001 certified. Micron's molding capacity ranges from 15 to 300 tons and includes a class 10,000 clean room used for processes sensitive to environmental particulates. In addition, this facility includes a new climate-controlled space for the manufacture of metal medical devices utilizing the latest in 5-axis CNC technology.

Inventory Requirements

Our larger customers benefit from our ability to maintain an inventory of standard sensors and snaps. This inventory policy allows for predictable and planned production resulting in cost efficiencies that we endeavor to pass on to our customers.

Custom molded product is manufactured on an order by order basis. Finished goods inventory is product made in advance of an acknowledged sales order, part of an annual blanket order quantity, or for a specific safety stock requested by the customer.

Research and Development

ART's research and development efforts focus primarily on maintaining the software library in the SAECG product lines in a compatible platform. Although base development work on Predictor 7 has been completed, the Company continues to provide technical support to the National Institutes of Health's research project utilizing ART's software. Included in this expense is development work to verify the integrity of the analytical algorithms, and improve the stability of the software on various platforms. For the fiscal years ended December 31, 2008 and 2007, ART had research and development expenses of approximately \$69,779 and \$38,900, respectively.

In 2008 and 2007, Micron's research and development efforts resulted in \$250,261 and \$73,500 of expense. These efforts include the development of a unique process to eliminate certain hazardous materials from our manufacturing processes. The 2008 expense included \$52,000 for equipment tested in a process improvement project for the sensor product line as well as the impairment of equipment used for final product testing.

Patents and Proprietary Technology

ART acquired three patents related to time and frequency domain analysis of electrocardiogram signals in 1993. The technologies are utilized in the current version of Predictor[®] 7. ART acquired U.S. Patent No. 5,117,833 entitled "*Bi-Spectral Filtering of Electrocardiogram Signals to Determine Selected QRS Potentials*," (the "Bi-Spec Patent") which expires in 2009. ART also acquired additional patents, which cover the spectral-temporal, mapping post-processing software packages. In March 1997, the U.S. Patent Office granted United States Patent No. 5,609,158 entitled "*Apparatus and Method for Predicting Cardiac Arrhythmia, by Detection of Micropotentials and Analysis of all ECG Segments and Intervals*" which covers a frequency domain analysis technique for SAECG data.

The Company believes that ART's products do not and will not infringe on patents or violate proprietary rights of others. In the event that ART's products infringe patents or proprietary rights of others, ART may be required to modify the design of its products or obtain a license. There can be no assurance that ART will be able to do so in a timely manner upon acceptable terms and conditions. In addition, there can be no assurance that ART will have the financial or other resources necessary to enforce or defend a patent infringement or proprietary rights violation action. Moreover, if ART's products infringe patents or proprietary rights of others, ART could, under certain circumstances, become liable for damages, which could have a material adverse effect on earnings.

Micron employs a highly complex, proprietary non-patented multi-step manufacturing process for its silver / silver chloride-plated sensors. To maintain our trade secrets associated with the manufacture of disposable electrode sensors, all employees are required to sign non-disclosure and/or non-competition agreements. Micron uses a patented material in the production of some sensors. Micron paid \$4,288 in 2008, and \$7,200 in 2007 in royalties associated with this patent. A provisional patent application was filed for a new type of product for the electrode industry.

Government Regulation

ART's software products are subject to, and ART believes currently comply with, material clearance and distribution requirements from governmental regulatory authorities, principally the U.S. Food and Drug Administration (FDA) and the European Union (EU) equivalent agency. These agencies promulgate quality system requirements under which a medical device is to be developed, validated and manufactured. The development of the product line will be managed in accordance with applicable regulatory requirements.

Micron's sensor elements are components used in medical devices designed and manufactured by original equipment manufacturers. As such, these elements are not required to be listed with regulatory agencies and do not require regulatory clearance for distribution. However, because Micron primarily distributes sensors to manufacturers for use in finished medical devices, Micron exercises as stringent controls over its manufacturing processes and finished products as would be required if the sensors were considered medical devices.

The NEM and MIT divisions manufacture parts for invasive medical devices, components for medical equipment, patented disposable medical laboratory products, and patented military applications. Our customers own the product designs and are, therefore, subject to FDA, Department of Defense and EU regulations. While such products are a part of a medical device or other regulated equipment, our customers are the regulated entity for the clearance of those products. NEM and MIT exercise stringent controls over all their manufacturing operations, and comply with any special controls required by their customers.

Environmental Regulation

Micron's operations involve use of hazardous and toxic materials, and generate hazardous, toxic and other wastes. Its operations are subject to federal, state and local laws and regulations governing the use, storage, handling and disposal of such materials and certain waste products. Although management believes that our safety procedures for using, handling, storing and disposing of such materials comply with these standards required by state and federal laws and regulations, we cannot completely eliminate the risk of accidental contamination or injury from these materials.

Since its inception, Micron has expended significant funds to train its personnel, install waste treatment and recovery equipment and to retain an independent environmental consulting firm to regularly review, monitor and upgrade its air and waste water treatment activities. Management continues to evaluate and test many possible technological advances that reduce or eliminate the need for and use of hazardous materials in our processes. The acquisition of equipment to eliminate a hazardous chemical from the process further emphasizes the commitment to the reduction and elimination of certain hazardous processes. Costs of compliance are not currently material to the Company's operation. Micron believes that the operation of its manufacturing facility is in compliance with currently applicable safety, health and environmental laws and regulations.

Employees

As of December 31, 2008, the Company had 81 full-time and 4 part-time employees. The employees of the Company are not represented by a union, and the Company believes its relationship with the employees is satisfactory.

Periodic Reporting and Financial Information

We have registered our common stock under the Securities Exchange Act of 1934, as amended, or the Exchange Act, and have reporting obligations, including the requirement that we file annual and quarterly reports with the SEC. The public may read and copy materials we file with the SEC at the SEC's Public Reference Room at 100 F Street, NE, Washington, DC 20549, on official business days during the hours of 10:00 am to 3:00 pm. You may obtain information about the operation of the Public Reference Room by calling the SEC at 1-800-SEC-0330. The SEC maintains an Internet site that contains reports, proxy and information statements, and other information regarding issuers that file electronically with the SEC at <http://www.sec.gov>.

Item 1A. RISK FACTORS.

Risk factors that may affect future operating results.

In addition to the other information in this Form 10-K, the following factors should be considered in evaluating the Company and its business. The risks and uncertainties described below are not the only ones facing the Company. Additional risks and uncertainties that the Company does not presently know or currently deems immaterial may also impair the Company's business, results of operations and financial condition.

The Company's operating results may fluctuate significantly as a result of a variety of factors.

Our operating results may fluctuate significantly in the future as a result of a variety of factors, many of which are outside of our control. These factors include:

- our ability to maintain our current pricing model and/or decrease our cost of sales;
- our ability to increase sales of higher margin products;
- variations in the mix of products sold;
- the level of demand for our products and services and those that we may develop;
- volatility in commodity and energy prices and our ability to offset higher costs with price increases;
- variability of customer delivery requirements;
- continued availability of supplies or materials used in manufacturing at competitive prices;
- the amount and timing of investments in capital equipment, sales and marketing, engineering and information technology resources; and
- general economic conditions.

As a strategic response to changes in the competitive environment, we may from time to time make certain pricing, service, technology or marketing decisions or business or technology acquisitions that could have a material adverse effect on our quarterly and annual results. Due to all of these factors, our operating results may fall below the expectations of securities analysts, stockholders and investors in any future period.

Large OEM customers can change their demand on short notice, further adding to the unpredictability of our quarterly sales and earnings.

Our quarterly results have in the past and may in the future vary due to the lack of dependable long-term demand forecasts from our larger OEM customers. In addition to this risk, many of our OEM customers have the right to change their demand schedule, either up or down, within a relatively short time horizon. These changes may result in us incurring additional working capital costs and causing increased manufacturing expenses due to these short-term fluctuations. In particular, our quarterly operating results have in the past fluctuated as a result of some of the larger OEM customers changing their orders within a fiscal quarter. Our expense levels and inventory, to a large extent, are based on shipment expectations in the quarter. If sales levels fall below these expectations, through a delay in orders or otherwise, operating results are likely to be adversely affected. Although we have tried to lessen our dependency on a few large customers, this is the nature of the OEM customers that we serve and we can provide no assurance that we will be able to materially alter this dependency in the immediate future, if at all.

If trade secrets are not kept confidential, the secrets may be used by others to compete against us.

Micron relies on unpatented trade secrets to protect its proprietary processes and there are no assurances that others will not independently develop or acquire substantially equivalent technologies or otherwise gain access to our proprietary process. Ultimately the meaningful protection of such unpatented proprietary technology cannot be guaranteed. The Company relies on confidentiality agreements with its employees. Remedies for any breach by a party of these confidentiality agreements may not be adequate to prevent such actions. Failure to maintain trade secret protection, for any reason, could have a material adverse effect on the Company.

Dependence on a limited number of customers.

In the fiscal years 2008 and 2007, 56% and 52%, respectively of the Company's revenues were derived from individual customers with 10% or more of the total sales. The loss of any one or more of these customers might have an immediate significant adverse effect on our financial results. In an effort to maintain this customer base, more favorable terms than might otherwise be agreed to could be granted. Currently, the Company generally does not receive purchase volume commitments extending beyond several months. Large corporations can shift focus away from a need for our product with little or no warning.

A significant portion of our revenues are derived from the sale of a single product line.

In fiscal years 2008 and 2007, the Company derived 42% and 49%, respectively, of its revenues from medical electrode sensors for use in disposable electrodes. While the technology in electrode sensors has been used for many years, there is no assurance that a new patented or unpatented technology might not replace the existing market for disposable electrode sensors. Any substantial technological advance that eliminates our product will have a material adverse effect on our operating results.

The Company is subject to stringent environmental regulations.

The Company is subject to a variety of federal, state and local requirements governing the protection of the environment. These environmental regulations include those related to the use, storage, handling, discharge and disposal of toxic or otherwise hazardous materials used in or resulting from the Company's manufacturing processes. Failure to comply with environmental law could subject the Company to substantial liability or force us to significantly change our manufacturing operations. In addition, under some of these laws and regulations, the Company could be held financially responsible for remedial measures if its properties are contaminated, even if it did not cause the contamination.

The Company may make acquisitions of companies, products or technologies that may disrupt the business and divert management's attention, adversely impacting our results of operations and financial condition.

The Company may make acquisitions of complementary companies, products or technologies from time to time. Any acquisitions will require the assimilation of the operations, products and personnel of the acquired businesses and the training and motivation of these individuals. Management may be unable to maintain and improve upon the uniform standards, controls, procedures and policies if the Company fails in this integration. Acquisitions may cause disruptions in operations and divert management's attention from day-to-day operations, which could impair our relationships with current employees, customers and strategic partners. The Company also may have to, or choose to, incur debt or issue equity securities to pay for any future acquisitions. The issuance of equity securities for an acquisition could be substantially dilutive to our stockholders' holdings. In addition, our profitability may suffer because of such acquisition-related costs or amortization costs for other intangible assets. If management is unable to fully integrate acquired businesses, products, technologies or personnel with existing operations, the Company may not receive the intended benefits of such acquisitions. The Company is not currently party to any agreements, written or oral, for the acquisition of any company, product or technology.

If the Company is unable to keep up with rapid technological changes, our processes, products or services may become obsolete and unmarketable.

The medical device and medical software industries are characterized by technological change over time. Although the Company attempts to expand our technological capabilities in order to remain competitive, discoveries by others may make our processes or products obsolete. If the Company cannot compete effectively in the marketplace, our potential for profitability and financial position will suffer.

The Company could become involved in litigation over intellectual property rights.

The medical device industry has been characterized by extensive litigation regarding patents and other intellectual property rights. Litigation, which would likely result in substantial cost to us, may be necessary to enforce any patents issued or licensed to us and/or to determine the scope and validity of others' proprietary rights. In particular, our competitors and other third parties hold issued patents and are assumed to hold pending patent applications, which may result in claims of infringement against us or other patent litigation. The Company also may have to participate in interference proceedings declared by the United States Patent and Trademark Office, which could result in substantial cost, to determine the priority of inventions.

A product liability suit could adversely affect our operating results.

The testing, manufacture, marketing and sale of medical devices of our customers entail the inherent risk of liability claims or product recalls. If our customers are involved in a lawsuit, it is foreseeable that the Company would also be named. Although the Company maintains product liability insurance, coverage may not be adequate. Product liability insurance is expensive, and in the future may not be available on acceptable terms, if at all. A successful product liability claim or product recall could have a material adverse effect on our business, financial condition, and ability to market product in the future.

The Company's conversion to a new enterprise resource planning solution may not provide expected benefits.

We have recently converted substantially all of our operational and financial functions to a new enterprise resource planning ("ERP") software system. The ERP system impacts every aspect of our operations, including production, engineering, finance, and sales. Although we have taken steps we believe are reasonable to ensure a successful conversion of our operations to the ERP system, we can provide no assurances that the conversion and continuous improvement of the system will be successful or that the ERP system will achieve its expected benefits. Failure to achieve a successful conversion or to obtain the expected benefits of the ERP system could have an adverse material effect on us.

The Company may be exposed to potential risks relating to our internal control over financial reporting and our ability to have those controls attested to by our independent registered public accounting firm.

As directed by Section 404 of the Sarbanes-Oxley Act of 2002 ("SOX 404"), the Securities and Exchange Commission adopted rules requiring public companies to include a report of management on the company's internal control over financial reporting in their annual reports, including Form 10-K. In addition, the independent registered public accounting firm auditing a company's financial statements must also attest to and report on management's assessment of the effectiveness of the company's internal control over financial reporting as well as the operating effectiveness of the Company's internal controls. The Company was not subject to these requirements for the fiscal year ended December 31, 2008. We are evaluating our internal control systems in order to allow our management to report on, and our independent auditors attest to, our internal controls, as a required part of our Annual Report on Form 10-K beginning with our report for the fiscal year ended December 31, 2009.

While we expended significant resources beginning in the latter part of 2008 to develop the necessary documentation and testing procedures required by SOX 404, there is a risk that we will not comply with all of the requirements imposed thereby. In the event the Company no longer qualifies as a smaller reporting company at the end of 2009, we may be subject to more stringent requirements under SOX 404. Accordingly, there can be no assurance that the Company will receive any required attestation from the independent registered public accounting firm. In the event we identify significant deficiencies or material weaknesses in our internal controls that we cannot remediate in a timely manner or we are unable to receive an attestation from the independent registered public accounting firm with respect to our internal controls, investors and others may lose confidence in the reliability of our financial statements and our ability to obtain equity or debt financing could suffer.

Item 2. PROPERTIES.

The manufacturing facility and offices of the Company are located in two buildings in an industrial area in Fitchburg, Massachusetts. The first building, which was purchased in April 1994, consists of a 22,000 square foot, six story building. The second building, which was purchased in September 1996, is over 94,000 square feet, including an antique brick three story mill building. Commencing in 2003, the 40,000 square foot "Mill" building portion of the second building underwent major renovations to preserve and create functional space from a previously unusable section of the facility. The renovations created space currently occupied by the NEM and MIT divisions. From October 2006 to February 2007, a third building of approximately 40,000 square feet, a fourth building of 12,000 square feet and vacant parcel between the buildings that abut the complex were acquired without any specific requirement for space. The Company believes the acquisition of the adjacent property positions the Company for continued growth in its current location. The Company believes its current facilities are sufficient to meet current and future production needs through fiscal year ending December 31, 2009.

Item 3. LEGAL PROCEEDINGS.

The Company is from time to time subject to legal proceedings, threats of legal action and claims which arise in the ordinary course of our business. Management believes the resolution of these matters will not have a material adverse effect on the results of operations or financial condition.

Item 4. SUBMISSION OF MATTERS TO A VOTE OF SECURITY HOLDERS.

No matters were submitted to a vote of security holders during the fourth quarter of 2008.

PART II

Item 5. MARKET FOR REGISTRANT'S COMMON EQUITY, RELATED STOCKHOLDER MATTERS AND ISSUER PURCHASES OF EQUITY SECURITIES.

ART's Common Stock has been listed on the NYSE AMEX, formerly the American Stock Exchange, since March 3, 1992 and trades under the ticker symbol HRT.

The following table sets forth, for the period indicated, the high and low sale prices per share for ART's Common Stock as quoted by the NYSE AMEX.

	High	Low
Year Ended December 31, 2008		
1st Quarter.....	\$ 9.30	\$ 5.00
2nd Quarter	7.00	5.40
3rd Quarter.....	6.03	3.25
4th Quarter	3.98	1.70
Year Ended December 31, 2007		
1st Quarter.....	\$ 33.89	\$ 20.10
2nd Quarter	26.76	11.05
3rd Quarter.....	14.27	8.48
4th Quarter	11.25	6.75

As of March 1, 2009 the number of record holders of ART's common stock is estimated to be 300 not including beneficial holders of our common stock held in street name.

Dividend Policy

No dividends were declared in 2008 or 2007. Future determination as to the payment of cash dividends, if any, will be at the discretion of the Board of Directors and will be dependent upon the Company's financial condition, results of operations, capital requirements, potential acquisitions, and other such factors as the Board of Directors may deem relevant, including any restrictions under any credit facilities in place now or in the future. The Company's demand line of credit agreement contains conditions including prior notification of the payment of dividends.

Equity Compensation Plan Information

The following table provides information, as of December 31, 2008, with respect to our equity compensation plans:

Plan Category	Number of securities to be issued upon exercise of outstanding options, warrants and rights (a)	Weighted-average exercise price of outstanding options, warrants and rights (b)	Number of securities remaining available for future issuance under equity compensation plans (excluding securities reflected in column (a)) (c)
Equity compensation plans approved by security holders	208,000	\$ 8.75	239,000 ⁽¹⁾
Equity compensation plans not approved by security holders	-	-	-
Total	208,000	\$ 8.75	239,000 ⁽¹⁾

⁽¹⁾ Includes 139,000 shares available under the 2001 Stock Option Plan and 100,000 shares available under the 2005 Stock Award Plan.

Recent Sales of Unregistered Securities

None

Purchases of Equity Securities

On October 3, 2008, our Board of Directors authorized the repurchase in the open market from time to time of up to \$650,000 of our common stock. The following table presents our repurchases in the open market during the fourth quarter of 2008:

Period	Total number of shares purchased	Average price paid per share	Total number of shares purchased as part of a publicly announced program	Approximate dollar value of shares that may yet be purchased under the program
October 1-31, 2008	-	-	-	\$ 650,000
November 1-30, 2008	15,717	\$ 2.21	15,717	615,250
December 1-31, 2008	7,672	2.51	7,672	596,025
Totals	23,389	\$ 2.36	23,389	\$ 596,025

The Company's purchases are subject to trading restrictions including average volume of shares traded over the previous four weeks, which greatly reduced our ability to repurchase shares.

Item 6. SELECTED FINANCIAL INFORMATION.

Not Applicable

Item 7. MANAGEMENT'S DISCUSSION AND ANALYSIS OF FINANCIAL CONDITION AND RESULTS OF OPERATION.

The following discussions of the Company's results of operations and financial condition should be read in conjunction with the consolidated financial statements and notes pertaining to them that appear elsewhere in this Form 10-K.

Any forward looking statements made herein are based on current expectations of the Company that involve a number of risks and uncertainties and should not be considered as guarantees of future performance. These statements are made under the Safe Harbor Provisions of the Private Securities Litigation Reform Act of 1995. Forward looking statements may be identified by the use of words such as "expect," "anticipate," "believe," "intend," "plans," "predict," or "will".

Although the Company believes that our expectations are based on reasonable assumptions, we can give no assurance that our expectations will materialize. Many factors could cause actual results to differ materially from our forward looking statements. Several of these factors include, in addition to those contained in "Factors that may affect future operating results," without limitation:

- our ability to maintain our current pricing model and/or decrease our cost of sales;*
- a stable interest rate market and/or a stable currency rate environment in the world, and specifically the countries we are doing business in or plan to do business in;*
- continued availability of supplies or materials used in manufacturing at competitive prices;*
- volatility in commodity and energy prices and our ability to offset higher costs with price increases;*
- adverse regulatory developments in the United States or any other country we plan to do business in;*
- entrance of competitive products in our markets;*
- the ability of management to execute plans and motivate personnel in the execution of those plans;*
- no adverse publicity related to our products or the Company;*
- no adverse claims relating to our intellectual property;*
- the adoption of new, or changes in, accounting principles;*
- the passage of new, or changes in, regulations; legal proceedings;*
- our ability to maintain compliance with the NYSE AMEX requirements for continued listing of our common stock;*
- the costs inherent with complying with new statutes and regulations applicable to public reporting companies, such as the Sarbanes-Oxley Act of 2002;*
- our ability to efficiently integrate future acquisitions and other new lines of business that the Company may enter in the future, if any; and*
- other risks referenced from time to time elsewhere in this report and in our filings with the SEC.*

The Company is under no obligation and does not intend to update, revise or otherwise publicly release any revisions to these forward-looking statements to reflect events or circumstances after the date hereof or to reflect the occurrence of any unanticipated events.

Results of Operations

The Company’s primary source of revenue relates to the manufacturing of components, devices and equipment primarily for the medical and defense industries. The single largest category of revenue relates to Micron’s production and sale of silver/silver chloride coated and conductive resin sensors used as component parts in the manufacture of integrated disposable electrophysiological sensors. These disposable medical devices are used worldwide in the monitoring of electrical signals in various medical applications. In an effort to leverage current skills, the Company has expanded into custom thermoplastic injection molded products and product life cycle management. This sector includes revenues from both high volume precision injection molding and custom injection molding. With the addition of a medical machining cell in 2007, the Company began production of patient specific metal medical devices. Management continues to identify complementary and/or synergistic products, technologies and lines of business in an effort to broaden the Company’s offerings.

The following table sets forth for the periods indicated, the percentages of the net sales represented by certain items reflected in the Company’s statements of operations.

	Years ended December 31,	
	2008	2007
Net sales	100.0%	100.0%
Cost of sales.....	81.0	75.5
Gross profit.....	19.0	24.5
Selling and marketing	3.5	3.9
General and administrative.....	11.3	10.9
Research and development	1.4	0.6
Other income, net.....	0.0	0.0
Income before income tax provision.....	2.8	9.1
Income tax provision.....	1.2	2.5
Net income.....	1.6%	6.6%

Net Sales

Net sales for 2008 were \$22,482,219, an increase of \$2,994,457 or 15%, when compared to the total net sales of \$19,487,762 in 2007. The disposable electrode sensor business continues to experience extreme price pressure in an increasingly competitive market. The revenue associated with the sensor business, including silver surcharge, decreased by \$112,584 as a result of price erosion and the loss of market share in Canada and Europe. The complementary metal snap business increased by \$44,170. The growth of the NEM and MIT divisions increased revenue by \$2,928,841. Included in the increase is \$3,800,000 of sales related to imported forgings that are being phased out in the first three months of 2009. Due to a change in customer demands, the precision molded products from Micron Products decreased approximately \$72,981 when compared to 2007. LTD increased revenues by \$118,137 excluding internal work for other divisions when compared to 2007. The remaining increase of \$89,525 was related to the snap assembly machine business and other miscellaneous revenues. Included in the revenues detailed above, non-recurring engineering and tooling revenue accounted for over \$214,000 of the revenues in 2008 as compared to \$380,000 in 2007. Engineering and tooling revenues typically occur at the beginning of a product life cycle or when a customer changes its manufacturing source. After the design and manufacture of the prototype and/or production tooling, the Company should benefit from product sales as it begins to utilize the customer owned tooling. There were no sales of SAECG software in either 2008 or 2007.

Cost of Sales

Cost of sales was \$18,204,526 (81% of net sales) in 2008 compared to \$14,709,035 (75.5% of net sales) in 2007 an increase of \$3,495,491 or 24%. A significant portion of the increase in cost of sales can be attributed to material costs. Gross margin is negatively affected by the increase in material costs as not all increases can be passed along to the customer in the form of price increases or surcharges. Silver pricing has generally been passed on to our customers in the form of a surcharge, but this does not preclude the Company from being pressured to reduce its margins as the price continues to climb. Silver surcharge collected from our customers is approximately 13% and 14%

of total net sales for years ended December 31, 2008 and 2007, respectively. Energy costs for 2008 were \$223,000 higher than 2007. The stabilization of manufacturing costs continues to be a major focus of management efforts. The forged products in the MIT division had higher than expected costs as quality problems from a subcontractor required extensive internal time and effort and freight costs exceeded expectations for most of 2008. All current products, services and programs, including those in development, are being evaluated for contribution and value to our overall business strategy and results. Products, services and programs that are underperforming from an overall contribution standpoint and not expected to improve will be phased out or discontinued so that the Company's resources can be put to use in developing those of more strategic value.

Selling and Marketing

Selling and marketing expenses increased to \$781,456 (3.5% of net sales) in 2008 from \$764,021 (3.9% of net sales) in 2007, an increase of \$17,435, or 2%. This increase in selling and marketing expense is mainly attributable to the commissions payable to the sales and business development personnel along with increased travel and trade show costs incurred as business development and marketing efforts were expanded. Management believes this increase to be nominal and expects the expense as a percentage of sales to continue to decrease as the Company begins to see positive results from the increase in business development efforts.

General and Administrative Expenses

General and administrative expenses were \$2,536,648 (11.3% of net sales) in 2008 as compared to \$2,131,694 (10.9% of net sales) in 2007, an increase of \$404,954 or 19%. Included in the increase of expense for the year ended December 31, 2008 is a one time charge of \$250,000 for costs associated with a terminated acquisition following due diligence. During this same period, the cost of additional administrative personnel of \$32,000, and \$71,000 of additional depreciation for the technology upgrades in preparation for Section 404 of the Sarbanes-Oxley Act of 2002 ("SOX") compliance increased the expense when compared to the similar period in 2007. Although the delay by the SEC for outside auditor attestation requirements of SOX Section 404 will limit a previously expected increase in audit fees for 2008, the costs associated with internal control documentation with outside consultants cost \$88,258 for the twelve months in 2008, and continues as planned. The new enterprise resource planning solution continues to improve data collection and reporting in all aspects of the business.

Research and Development

Research and development costs increased to \$320,040 (1.4% of net sales) in 2008 from \$112,472 (0.6% of net sales) in 2007, an increase of \$207,567, or 185%. For the fiscal years ended December 31, 2008, and 2007, ART had research and development expenses of approximately \$69,779 and \$36,501, respectively. Expenses include the technical support of a National Institutes of Health research project utilizing ART's proprietary Signal Averaged ECG products and patented algorithms. In 2008 and 2007, Micron's research and development efforts resulted in \$250,261 and \$73,500 of expense. The expense is associated with continued work on patentable technologies and process improvements on the Micron sensor and snap product lines. The twelve months ended December 31, 2008 included \$52,000 of expense for equipment tested in a process improvement project with the sensor product line as well as the impairment of equipment used for final product testing.

Interest Expense

Interest expense was \$46,230 in 2008 compared to \$21,188 in 2007, an increase of \$25,042, or 118%. This expense is a result of the acquisition note and an equipment loan. The Company does not incur an unused borrowing base fee under our unsecured credit facility.

Other Income

Other income was \$29,464 in 2008 compared to \$27,711 in 2007, an increase of \$1,753, or 6%. The majority of other income was bank interest of \$29,861 and \$34,299, in 2008 and 2007, respectively. Lower average balances and a decrease in the rate of return account for the decrease in interest income. The remainder of other income was from miscellaneous expense items including a loss in the disposal of assets, and currency losses relating to a foreign government's import taxes and the timing of the reimbursement.

Income Taxes

The Company's combined federal and state effective income tax rate was 42% and 28% in 2008 and 2007, respectively. The effective rates in 2007 were lower than the statutory rates primarily due to the reductions in tax from tax credits. In 2007, the Company utilized all remaining federal net operating loss carryforwards. During the third

quarter of 2007, the IRS completed its audit of the Company's tax returns for several prior periods, and did not require any changes to be made to those returns.

Goodwill

As of December 31, 2008, the Company's goodwill of \$1,564,966 is related to three reporting units, \$1,244,000 associated with the acquisition of Micron Products, Inc. in 1992, \$235,727 associated with the acquisition of Shrewsbury Molders, Inc. in 2004, and \$85,239 associated with the acquisition of Leominster Tool Co. Inc. in December 2006. There was no impairment to the goodwill associated with or expected in any acquisition based on the first quarter annual impairment test in 2008.

Earnings Per Share

The basic earnings per share was \$0.13 in 2008 as compared to \$0.47 in 2007, a decrease of \$0.34, or 72%. The increase in expenses described above had a direct impact to the earnings per share when comparing 2008 to 2007. The decrease in earnings per share for 2008 includes non-recurring charges totaling \$302,000, related to an acquisition and research and development activities. This charge, net of tax, decreased basic earnings per share for 2008 by \$0.07.

Off-Balance Sheet Arrangements

The Company does not have any off balance sheet arrangements.

Liquidity and Capital Resources

Working capital was \$7,440,721 as of December 31, 2008 as compared to \$6,454,847 as of December 31, 2007, as restated. Operating results produced positive cash flows of \$1,937,379 of which \$1,015,702 was spent on capital asset investment. Cash and cash equivalents were \$2,320,467 and \$1,684,411 at December 31, 2008, and 2007, respectively. Substantially all of these funds are invested in fixed rate bank instruments that are highly liquid.

Inventories increased to \$3,727,492 at the end of 2008, an increase of \$725,972 from the end of 2007. The increased inventory was the result of raw material requirements, the rising cost of silver and higher unit cost of resins purchased. Several factors contributed to the increase in finished goods inventory. The MIT division had product shipments in the first week of 2009 which were built in 2008. In the NEM division, the ability to produce in longer runs lowers the per unit cost of the product while increasing the finished goods inventory. For one major Micron sensor customer, larger inventories of particular sensors are held in finished goods in an effort to decrease delivery time. The quantity of this sensor inventory maintained has not materially changed, but the cost of silver has increased resulting in higher inventory balances.

Net capital equipment expenditures were \$1,015,702 in 2008 as compared to \$2,638,000 in 2007. In 2008, the majority of the expenditures were for the acquisition of additional production machinery and equipment, including upgrades in and replacement of existing machinery and tooling. A climate controlled mold manufacturing space built for LTD and the addition of an ultrasonic cleaning production line cost \$306,000 and \$55,000, respectively. In 2007, the largest expenditure of \$1,086,000 included the installation of four (4) machining centers and creation of a medical machining cell. This climate controlled space includes a computer programming office to control the machines and the latest in 5-axis three dimensional computer technology. The second largest expenditure of \$450,000 in computer software and equipment related to the installation and upgrade of our enterprise resource planning package. The total budget for this project is over \$500,000 and improves all aspects of the information technology at all levels of the organization. The software will ease the Company's transition with SOX Section 404 compliance, and is expected to facilitate integration of future acquisitions. Other administrative improvements included a new phone system, facility security and expansion of the internal network with full replication of data for disaster recovery. The majority of remaining capital expenditures related to manufacturing equipment replacements and additions including computer controlled inspection equipment.

In 2007, another adjoining property for an additional 13,000 square feet and vacant lot was purchased for \$205,000.

An unsecured \$1,000,000 credit facility was available in 2008 and 2007. The agreement provides for borrowings up to 80% of eligible accounts receivable plus 50% of raw material and finished goods inventories up to a \$300,000 maximum. This facility has no borrowing base charge. There were no outstanding borrowings on our line of credit as of December 31, 2008 and 2007. The agreement contains covenants that apply upon drawing on the line. The covenants relate to various matters including notice prior to executing further borrowings and security interests, merger or consolidation, acquisitions, guarantees, sales of assets other than in the normal course of business, leasing, changes in ownership and payment of dividends.

The Company has a one year term note secured by equipment with a limit of \$813,000. The loan was drawn down by \$383,000 for equipment delivered and installed in October 2007. A second payment of \$383,000 was made in January of 2008 for this equipment. In the third quarter of 2008 the equipment note was extended for one year with a decrease in the fixed rate from 6.75% to 6.5% per annum. The equipment note is amortized over 6 years with a balloon payment for the remaining balance at September 15, 2009.

Funding for future research and development is expected to be provided by ongoing operations, and at this time there are no plans for projects that would require outside funding.

In October 2008, the Company's Board of Directors authorized the repurchase in the open market from time to time of up to \$650,000 of the Company's outstanding stock. An aggregate of 23,389 shares were purchased in the fourth quarter under the program for an aggregate of \$53,975.

Inflation

The Company believes that inflation in the United States or international markets has not had a significant effect on its results of operations except for the impact of the increase in volatility of materials and energy prices particularly the cost of silver.

Recent Accounting Pronouncements

In September 2006, the FASB issued SFAS No. 157, *Fair Value Measurements*. SFAS No. 157 prescribes a single definition of fair value as the price that would be received to sell an asset or paid to transfer a liability in an orderly transaction between market participants at the measurement date. The Company does not believe the adoption of SFAS No. 157 will have a material impact on its financial condition or results of operations. SFAS No. 157 was effective for the Company's interim reporting period beginning January 1, 2008.

In February 2007, the FASB issued SFAS No. 159, *The Fair Value Option for Financial Assets and Financial Liabilities Including an Amendment of FASB Statement No. 115*. SFAS No. 159 permits an entity to elect fair value as the initial and subsequent measurement attribute for many financial assets and liabilities. Entities electing the fair value option would be required to recognize changes in fair value in earnings. Entities electing the fair value option would also be required to distinguish, on the face of the statement of financial position, the fair value of assets and liabilities for which the fair value option has been elected and similar assets and liabilities measured using another measurement attribute. The Company does not believe the adoption of SFAS No. 159 will have a material impact on its financial condition or results of operations. SFAS No. 159 was effective for the Company's interim reporting period beginning January 1, 2008.

In December 2007, the SEC issued SAB No. 110. SAB 110 allows for the continued use of a "simplified" method, as discussed in SAB No. 107, in developing an estimate of expected term of "plain vanilla" share options in accordance with SFAS 123 (revised 2004). Originally the staff stated in SAB 107 that it would not expect a company to use the simplified method for share option grants after December 31, 2007. Accordingly, the SEC staff will continue to accept, under certain circumstances, the use of the simplified method beyond December 31, 2007. The Company will continue the use of the simplified method for determining the value of options granted as allowed by SAB 110.

In December 2007, the FASB issued SFAS No. 141(R), *Business Combinations*. SFAS No. 141(R) establishes principles and requirements for how the acquirer of a business recognizes and measures in its financial statements the identifiable assets acquired, the liabilities assumed, and any noncontrolling interest in the acquiree. SFAS No. 141(R) also provides guidance for recognizing and measuring the goodwill acquired in the business combination and determines what information to disclose to enable users of the financial statements to evaluate the nature and financial effects of the business combination. The provisions of SFAS No. 141(R) are applicable to business combinations consummated on or after December 15, 2008 with early adoption prohibited.

In December 2007, the FASB issued SFAS No. 160, *Noncontrolling Interests in Consolidated Financial Statements - an amendment of ARB No. 51*. SFAS No. 160 establishes accounting and reporting standards for the noncontrolling interest in a subsidiary for the deconsolidation of a subsidiary. SFAS No. 160 is effective for financial statements issued for fiscal years beginning after December 15, 2008, and interim statements within those fiscal years. The Company does not currently have any noncontrolling interests.

Critical Accounting Policies

The preparation of financial statements and related disclosures in conformity with generally accepted accounting principles requires management to make judgments, assumptions and estimates that affect the amounts reported. Note 2 of Notes to Consolidated Financial Statements describes the significant accounting policies used in the

preparation of the consolidated financial statements. Certain of these significant accounting policies are considered to be critical accounting policies, as defined below.

A critical accounting policy is defined as one that is both material to the presentation of the Company's financial statements and requires management to make difficult, subjective or complex judgments that could have a material effect on the Company's financial condition and results of operations. Specifically, critical accounting estimates have the following attributes: 1) the Company is required to make assumptions about matters that are highly uncertain at the time of the estimate; and 2) different estimates the Company could reasonably have used, or changes in the estimate that are reasonably likely to occur, would have a material effect on the Company's financial condition or results of operations.

Estimates and assumptions about future events and their effects cannot be determined with certainty. The Company bases its estimates on historical experience and on various other assumptions believed to be applicable and reasonable under the circumstances. These estimates may change as new events occur, as additional information is obtained and as the Company's operating environment changes. These changes have historically been minor and have been included in the consolidated financial statements as soon as they became known. In addition, management is periodically faced with uncertainties, the outcomes of which are not within its control and will not be known for prolonged periods of time. These uncertainties are discussed in the section above entitled "*Factors that may affect future operating results.*" Based on a critical assessment of its accounting policies and the underlying judgments and uncertainties affecting the application of those policies, management believes that the Company's consolidated financial statements are fairly stated in accordance with generally accepted accounting principles, and present a meaningful presentation of the Company's financial condition and results of operations.

Management believes that the following are critical accounting policies:

Revenue Recognition and Accounts Receivable

The Company recognizes revenue upon product shipment, provided that there exists persuasive evidence of an arrangement, the fee is fixed or determinable, and collectability of the related receivable is reasonably assured.

The financing of customer purchased tooling utilizes the direct financing method of revenue recognition. This requires the gain or loss on the sale of the tooling to be recorded at the time the tool is put into service while the customer's stream of payments is reflected as a lease receivable.

Based on management's on-going analysis of accounts receivable balances, and after the initial recognition of the revenue, as to any event that adversely affects the ultimate ability to collect the related receivable, management will record an allowance for bad debts. Bad debts have not had a significant impact on the Company's financial position, results of operations and cash flows.

Inventory and Inventory Reserves

The Company values its inventory at the lower of average cost or market. The Company reviews its inventory for quantities in excess of production requirements, obsolescence and for compliance with internal quality specifications. Any adjustments to inventory would be equal to the difference between the cost of inventory and the estimated net market value based upon assumptions about future demand, market conditions and expected cost to distribute those products to market.

The Company maintains a reserve for excess, slow moving, and obsolete inventory as well as inventory with a carrying value in excess of its net realizable value. A review of inventory on hand is made at least annually and any provision for excess and obsolete inventory is recorded. The review is based on several factors including a current assessment of future product demand, historical experience, and product expiration.

Deferred Tax Assets

The Company assesses its deferred tax assets based upon a more likely than not to be realized criteria. The Company considers future taxable income and ongoing prudent and feasible tax planning strategies in assessing the need for the valuation allowance. In accordance with FIN 48 we recognize the benefits of a tax position if that position is more likely than not to be sustained on audit, based on the technical merit of the position.

Asset Impairment – Goodwill

The Company reviews the valuation of goodwill and intangible assets to assess potential impairments. Management reassesses the useful lives of other intangible assets with identifiable useful lives in accordance with the guidelines set forth in the Statement of Financial Accounting Standard No. 142, "*Goodwill and Other Intangible*

Assets". The value assigned to intangible assets is determined by a valuation based on estimates and judgment regarding expectations for the success and life cycle of products previously acquired or others likely to be acquired in the future. If the actual sale of product and market acceptance differs significantly from the estimates, management may be required to record an impairment charge to write down the asset to its realizable value. To test for impairment, a present value of an estimate of future cash flows related to goodwill or intangible assets with indefinite lives are calculated and compared to the value of the intangible asset during the first quarter annually. When impairment exists it could have a material adverse effect on the Company's business, financial condition and results of operations.

Asset Impairment – Long Lived Assets

The Company assesses the impairment of long-lived assets and intangible assets with finite lives whenever events or changes in circumstances indicate that the carrying value may not be fully recoverable. When the Company's management determines that the carrying value of such assets may not be recoverable, management generally measures any impairment on a projected discounted cash flow method using a discount rate determined by management to be commensurate with the risk inherent in its current business model.

Item 7A. QUANTITATIVE AND QUALITATIVE DISCLOSURES ABOUT MARKET RISK.

Not Applicable

Item 8. CONSOLIDATED FINANCIAL STATEMENTS.

The information required by this item may be found on pages F-1 through F-19 of this Annual Report on Form 10-K.

Item 9. CHANGES IN AND DISAGREEMENTS WITH ACCOUNTANTS ON ACCOUNTING AND FINANCIAL DISCLOSURES.

Not Applicable

Item 9A. CONTROLS AND PROCEDURES.

Evaluation of Disclosure Controls and Procedures

As of the end of the period covered by this annual report the Company's management, with the participation of the Company's Chief Executive Officer and Chief Financial Officer ("the Certifying Officer"), conducted evaluations of the Company's disclosure controls and procedures. As defined under Sections 13a – 15(e) and 15d – 15(e) of the Securities Exchange Act of 1934, as amended (the "Exchange Act"), the term "disclosure controls and procedures" means controls and other procedures of an issuer that are designed to ensure that information required to be disclosed by the issuer in the reports that it files or submits under the Exchange Act is recorded, processed, summarized and reported, within the time periods specified in the Commission's rules and forms. Disclosure controls and procedures include without limitation, controls and procedures designed to ensure that information required to be disclosed by an issuer in the reports that it files or submits under the Exchange Act is accumulated and communicated to the issuer's management, including the Certifying Officer, to allow timely decisions regarding required disclosure. Based on this evaluation, the Certifying Officer has concluded that the Company's disclosure controls and procedures were effective to ensure that material information is recorded, processed, summarized and reported by management of the Company on a timely basis in order to comply with the Company's disclosure obligations under the Exchange Act and the rules and regulations promulgated thereunder.

Changes in Internal Control over Financial Reporting

Further, there were no changes in the Company's internal control over financial reporting during the Company's last fiscal quarter that materially affected, or are reasonably likely to materially affect, the Company's internal control over financial reporting.

Management's Report on Internal Control over Financial Reporting

Our Chief Executive Officer ("CEO") and Chief Financial Officer ("CFO") are responsible for establishing and maintaining adequate internal control over financial reporting, as such term is defined in Rule 13a-15(f) of the Securities Exchange Act of 1934, as amended (the "Exchange Act").

Internal control over financial reporting is defined in Rule 13a-15(f) promulgated under the Exchange Act as a process designed by, or under the supervision of, our CEO and CFO and effected by our board of directors,

management and other personnel, to provide reasonable assurance regarding the reliability of financial reporting and the preparation of financial statements for external purposes in accordance with generally accepted accounting principles and includes those policies and procedures that:

- pertain to the maintenance of records that in reasonable detail accurately and fairly reflect the transactions and dispositions of our assets;
- provide reasonable assurance that transactions are recorded as necessary to permit preparation of financial statements in accordance with generally accepted accounting principles, and that our receipts and expenditures are being made only in accordance with authorizations of our management and directors; and
- provide reasonable assurance regarding prevention or timely detection of unauthorized acquisition or disposition of our assets that could have a material effect on the financial statements.

Readers are cautioned that internal control over financial reporting, no matter how well designed, has inherent limitations and may not prevent or detect misstatements. Therefore, even effective internal control over financial reporting can only provide reasonable assurance with respect to the financial statement preparation and presentation.

Our management, under the supervision and with the participation of our CEO and CFO, has evaluated the effectiveness of our disclosure controls and procedures as defined in Exchange Act Rules 13a-15(e) and 15d-15(e) as of the end of the period covered by this Report based upon the framework in Internal Control Integrated Framework issued by the Committee of Sponsoring Organizations of the Treadway Commission (COSO). Based on such evaluation, our management has made an assessment that our internal control over financial reporting is effective as of December 31, 2008.

This annual report does not include an attestation report of the Company's independent registered public accounting firm regarding internal control over financial reporting. Management's report was not subject to attestation by the Company's independent registered public accounting firm due to a transition period established by the rules of the Securities and Exchange Commission that permit the Company to provide only management's report in this annual report.

Item 9B. OTHER INFORMATION.

None.

PART III

Item 10. DIRECTORS, EXECUTIVE OFFICERS, PROMOTERS AND CORPORATE GOVERNANCE.

The information with respect to directors and executive officers required under this item is incorporated by reference to the applicable information set forth in our Proxy Statement for our 2009 Annual Meeting of Shareholders.

Item 11. EXECUTIVE COMPENSATION.

The information required under this item is incorporated by reference to the applicable information in our Proxy Statement for our 2009 Annual Meeting of Shareholders.

Item 12. SECURITY OWNERSHIP OF CERTAIN BENEFICIAL OWNERS AND MANAGEMENT AND RELATED STOCKHOLDER MATTERS.

The information required under this item is incorporated by reference to the applicable information in our Proxy Statement for our 2009 Annual Meeting of Shareholders.

Item 13. CERTAIN RELATIONSHIPS AND RELATED TRANSACTIONS AND DIRECTOR INDEPENDENCE.

The information required under this item is incorporated by reference to the applicable information in our Proxy Statement for our 2009 Annual Meeting of Shareholders.

Item 14. PRINCIPAL ACCOUNTANT FEES AND SERVICES.

The information required under this item is incorporated by reference to the applicable information in our Proxy Statement for our 2009 Annual Meeting of Shareholders.

PART IV

Item 15. EXHIBITS AND FINANCIAL STATEMENT SCHEDULES.

The Company hereby furnishes the exhibits listed on the attached exhibit index. Exhibits, which are incorporated herein by reference, may be inspected and copied at the public reference facilities maintained by the SEC at Room 1580, Washington, D.C. 20549. Copies of such material may be obtained by mail from the Public Reference Section of the SEC at 100 F Street, N.E., Washington, D.C. 20549, at prescribed rates. The SEC also maintains a website that contains reports, proxy and information statements and other information regarding registrants that file electronically with the SEC at the address "<http://www.sec.gov>".

SIGNATURES

Pursuant to the requirements of Section 13 or 15(d) of the Securities Exchange Act of 1934, the registrant caused this report to be signed on its behalf by the undersigned, thereunto duly authorized.

ARRHYTHMIA RESEARCH TECHNOLOGY, INC.

By: /s/ James E Rouse
James E. Rouse,
President and Chief Executive Officer
March 25, 2009

Pursuant to the requirements of the Securities Exchange Act of 1934, this report has been signed below by the following persons on behalf of the registrant and in the capacities and on the dates indicated.

Signature	Capacity	Date
<u>/s/ James E. Rouse</u> James E. Rouse	President, Chief Executive Officer and Director (Principal Executive Officer)	March 25, 2009
<u>/s/ David A. Garrison</u> David A. Garrison	Executive Vice President of Finance and Chief Financial Officer (Principal Financial and Accounting Officer)	March 25, 2009
<u>/s/ E. P. Marinos</u> E. P. Marinos	Chairman of the Board	March 25, 2009
<u>/s/ Julius Tabin</u> Julius Tabin	Director	March 25, 2009
<u>/s/ Paul F. Walter</u> Paul F. Walter	Director	March 25, 2009
<u>/s/ Jason R. Chambers</u> Jason R. Chambers	Director	March 25, 2009

**Arrhythmia Research Technology, Inc.
And Subsidiary**

Contents

Report of Independent Registered Public Accounting Firm	F-2
Consolidated Financial Statements:	
Balance sheets	F-3, F-4
Statements of income	F-5
Statements of changes in shareholders' equity	F-6
Statements of cash flows	F-7
Notes to consolidated financial statements	F-8 to F-19

Report of Independent Registered Public Accounting Firm

To the Board of Directors and the Shareholders of
Arrhythmia Research Technology, Inc.
Fitchburg, Massachusetts

We have audited the accompanying consolidated balance sheets of Arrhythmia Research Technology, Inc. and Subsidiary as of December 31, 2008 and 2007, and the related consolidated statements of income, changes in shareholders' equity and cash flows for the years then ended. These financial statements are the responsibility of the Company's management. Our responsibility is to express an opinion on these financial statements based on our audits.

We conducted our audits in accordance with standards of the Public Company Accounting Oversight Board (United States). Those standards require that we plan and perform the audit to obtain reasonable assurance about whether the financial statements are free of material misstatement. The Company is not required to have, nor were we engaged to perform, an audit of its internal control over financial reporting. Our audits included consideration of internal control over financial reporting as a basis for designing audit procedures that are appropriate in the circumstances, but not for the purpose of expressing an opinion on the effectiveness of the Company's internal control over financial reporting. Accordingly, we express no such opinion. An audit also includes examining, on a test basis, evidence supporting the amounts and disclosures in the financial statements, assessing the accounting principles used and significant estimates made by management, as well as evaluating the overall financial statement presentation. We believe that our audits provide a reasonable basis for our opinion.

In our opinion, the consolidated financial statements referred to above present fairly, in all material respects, the financial position of Arrhythmia Research Technology, Inc. and Subsidiary as of December 31, 2008 and 2007, and the results of their operations and their cash flows for the years then ended, in conformity with accounting principles generally accepted in the United States of America.

/s/ CCR LLP
Westborough, Massachusetts
March 25, 2009

Arrhythmia Research Technology, Inc.
and Subsidiary
Consolidated Balance Sheets

<i>December 31,</i>	2008	2007 <i>Restated</i>
Assets		
Current assets:		
Cash and cash equivalents	\$ 2,320,467	\$ 1,684,411
Trade accounts receivable, net of allowance for doubtful accounts of \$45,619 and \$49,830	2,705,145	2,759,491
Inventories (Note 3)	3,727,492	3,001,520
Deferred income taxes (Note 6)	21,000	35,000
Prepaid tax	309,000	400,395
Deposits, prepaid expenses and other current assets	392,209	429,375
 Total current assets	 9,475,313	 8,310,192
 Property, plant and equipment, net (Note 4)	 7,305,278	 7,610,258
 Goodwill (Note 2)	 1,564,966	 1,564,966
 Other intangible assets, net	 143,010	 221,482
 Other assets	 -	 24,785
 Total assets	 \$ 18,488,567	 \$ 17,731,683

See accompanying notes to consolidated financial statements.

**Arrhythmia Research Technology, Inc.
and Subsidiary**

Consolidated Balance Sheets

(Continued)

<i>December 31,</i>	2008	2007 <i>Restated</i>
Liabilities and Shareholders' Equity		
Current liabilities:		
Accounts payable	\$ 1,106,974	\$ 633,413
Accrued expenses	289,527	352,194
Current portion of acquisition note payable (Note 2)	-	134,083
Current note payable	638,091	735,655
Total current liabilities	2,034,592	1,855,345
Long term liabilities:		
Long term deferred tax liability (Note 6)	315,500	145,500
Total long term liabilities	315,500	145,500
Total liabilities	2,350,092	2,000,845
Commitments and contingencies (Note 8):		
Shareholders' equity (Notes 7 and 10):		
Common stock, \$.01 par value; 10,000,000 shares authorized; 3,926,491 issued, 2,688,291 and 2,711,680 outstanding respectively	39,265	39,265
Additional paid-in-capital	10,243,568	10,143,339
Treasury stock at cost, 1,238,200 and 1,214,811 shares respectively	(3,380,554)	(3,326,579)
Retained earnings	9,236,196	8,874,813
Total shareholders' equity	16,138,475	15,730,838
Total liabilities and shareholders' equity	\$ 18,488,567	\$ 17,731,683

See accompanying notes to consolidated financial statements.

**Arrhythmia Research Technology, Inc.
and Subsidiary**

Consolidated Statements of Income

<i>Years ended December 31,</i>	2008	2007
Net sales (Note 12)	\$ 22,482,219	\$ 19,487,762
Cost of sales	18,204,526	14,709,035
Gross profit	4,277,693	4,778,727
Selling and marketing	781,456	764,021
General and administrative	2,536,648	2,131,694
Research and development	320,040	112,472
Income from operations	639,549	1,770,540
Other income (expense):		
Interest expense	(46,230)	(21,188)
Other income	29,464	27,711
Total other income (expense)	(16,766)	6,523
Income before income taxes	622,783	1,777,063
Income tax provision (Note 6)	261,400	490,000
Net income	\$ 361,383	\$ 1,287,063
Earnings per share (Note 2):		
Basic	\$ 0.13	\$ 0.47
Diluted	\$ 0.13	\$ 0.47

See accompanying notes to consolidated financial statements.

Arrhythmia Research Technology, Inc.
and Subsidiary
Consolidated Statements of Changes in Shareholder's Equity
(Notes 1, 2 and 7)

	Common Stock		Additional	Treasury	Retained	Total
	Shares	Amount	Paid-in Capital	Stock	Earnings	
December 31, 2006, as filed	3,926,491	\$ 39,265	\$ 10,021,417	\$ (3,343,007)	\$ 7,702,450	\$ 14,420,125
Prior period adjustment					(114,700)	(114,700)
December 31, 2006, as adjusted	3,926,491	\$ 39,265	\$ 10,021,416	\$ (3,343,007)	\$ 7,587,750	\$ 14,305,425
Share based compensation			45,641			45,641
Tax benefit from exercise of stock options			33,549			33,549
Stock issued with exercise of stock options			42,732	16,428		59,160
Net income					1,287,063	1,287,063
December 31, 2007	3,926,491	\$ 39,265	\$ 10,143,339	\$ (3,326,579)	\$ 8,874,813	\$ 15,730,838
Share based compensation			100,229			100,229
Treasury stock repurchased 23,389 shares				(53,975)		(53,975)
Net income					361,383	361,383
December 31, 2008	3,926,491	\$ 39,265	\$ 10,243,568	\$ (3,380,554)	\$ 9,236,196	\$ 16,138,475

See accompanying notes to consolidated financial statements.

Arrhythmia Research Technology, Inc.
and Subsidiary
Consolidated Statements of Cash Flows
(Note 9)

<i>Years ended December 31,</i>	2008	2007
Cash flows from operating activities:		
Net income	\$ 361,383	\$ 1,287,063
Adjustments to reconcile net income to net cash provided by operating activities:		
Depreciation and amortization	1,399,154	1,148,463
Provision for doubtful accounts	(4,211)	20,000
Deferred income tax provision	184,000	220,000
Share based compensation	100,229	45,641
Changes in operating assets and liabilities:		
Trade accounts receivable	58,557	78,446
Inventories	(725,972)	(133,228)
Deposits, prepaid expenses and other assets	153,346	(391,948)
Accounts payable and accrued expenses	410,894	(802,432)
Net cash provided by operating activities	1,937,380	1,472,005
Cash flows from investing activities:		
Capital expenditures, net of disposals	(1,015,702)	(1,884,315)
Net cash (used in) investing activities	(1,015,702)	(1, 884,315)
Cash flows from financing activities:		
Payments to notes payable	(231,647)	(61,633)
Proceeds from exercise of stock options	-	59,160
Tax benefit from exercise of stock options	-	33,549
Repurchase of stock	(53,975)	-
Net cash (used in) provided by financing activities	(285,622)	31,076
Net (decrease) increase in cash and cash equivalents	636,056	(381,234)
Cash and cash equivalents, beginning of year	1,684,411	2,065,645
Cash and cash equivalents, end of year	\$2,320,467	\$1,684,411

See accompanying notes to consolidated financial statements.

1. Description of Business

Arrhythmia Research Technology, Inc. (“ART”) is engaged in the licensing of medical software, which acquires data and analyzes electrical impulses of the heart to detect and aid in the treatment of potentially lethal arrhythmias. Micron Products, Inc. (“Micron”), a wholly owned subsidiary, is the primary source of consolidated revenues. Micron manufactures disposable electrode sensors used as a component part in the manufacture of integrated disposable electro-physiological sensors. These disposable medical devices are used worldwide in the monitoring of electric signals in various medical applications. Micron has expanded into custom plastic injection molded products and product life cycle management. Revenues in this sector are primarily custom injection molding, and end-to-end product life cycle management through a comprehensive portfolio of value-added services such as design, engineering, prototyping, manufacturing, machining, assembly and packaging.

2. Accounting Policies

Principles of Consolidation

The consolidated financial statements include the accounts of ART and Micron (collectively the “Company”). All intercompany balances and transactions have been eliminated in consolidation.

Revenue Recognition

The Company recognizes revenue upon product shipment, provided that there exists persuasive evidence of an arrangement, the fee is fixed or determinable, and collectability of the related receivable is reasonably assured.

Financing Customer Purchased Tooling

In order to lessen the impact of the initial cost of a custom mold, Micron provides a tooling financing package for select customers. The cost of the tool is charged in conjunction with the product shipments over the first 3 or 4 years of the agreed upon purchasing program. The customer agrees to pay for the tool in full upon any delay or termination in the program. The income is recognized utilizing the direct financing method.

Cash and Cash Equivalents

Cash and cash equivalents consist of cash on hand and on deposit in high quality financial institutions. The Company considers all highly liquid debt instruments with original maturities of three months or less to be cash equivalents.

Inventories

Inventories are stated at the lower of average cost or market. Silver is inventoried with approximately one month’s usage and is not re-priced as inventory turns make the changes immaterial. Cost of inventories is determined by the first-in, first-out method.

Concentration of Credit Risk

Financial instruments which potentially expose the Company to concentrations of credit risk, as defined by Statement of Financial Accounting Standard (“SFAS”) No. 105, Disclosure of Information about Financial Instruments with Off-Balance-Sheet Risk and Financial Instruments with Concentrations of Credit Risk, consist primarily of trade accounts receivable and cash and cash equivalents.

Accounts receivable are customer obligations due under normal trade terms. A large portion of Micron’s products are sold to large diversified medical and defense product manufacturers. The Company does not generally require collateral for its sales; however, the Company believes that its terms of sale provide adequate protection against significant credit risk.

Senior management regularly reviews accounts receivable to determine if any receivables will potentially be uncollectible. The Company includes any accounts receivable balances that are determined to be uncollectible, along with a general reserve, in our overall allowance for doubtful accounts. After all attempts to collect a receivable have failed, the receivable is written off against the allowance. Based on the information available to us, management believes the allowance for doubtful accounts as of December 31, 2008 is adequate. However, actual write offs might exceed the recorded allowance.

2. Accounting Policies (Continued)

Concentration of Credit Risk (Continued)

It is the Company's policy to place its cash and cash equivalents in high quality financial institutions. The Company does not believe significant credit risk exists above federally insured limits with respect to these institutions.

Property, Plant and Equipment

Property, plant and equipment are recorded at cost and include expenditures which substantially extend their useful lives. Depreciation on property, plant and equipment is calculated using the straight-line method over the estimated useful lives of the assets. Expenditures for maintenance and repairs are charged to earnings as incurred. When equipment is retired or sold, the resulting gain or loss is reflected in earnings.

Goodwill

The Company accounts for goodwill and intangibles in accordance with SFAS No. 142, Goodwill and Other Intangible Assets. SFAS No. 142 requires that companies test goodwill for impairment at least annually. In addition, SFAS No. 142 requires that the Company identify reporting units for the purpose of assessing potential future impairments of goodwill, reassess the useful lives of other existing recognized intangible assets, and cease amortization of intangible assets with an indefinite useful life. An intangible asset with an indefinite useful life should be tested for impairment in accordance with the guidelines in SFAS No. 142. SFAS No. 142 is required to be applied to all goodwill and other intangible assets regardless of when those assets were initially recognized.

There was no impairment to goodwill as of first quarter of 2008 and no indicators have arisen to require the Company to review goodwill in the interim period. The Company performs its annual impairment testing for the goodwill valuation during the first quarter of the fiscal year.

Long-Lived Assets

The Company accounts for long lived assets in accordance to the SFAS No. 144, Accounting for the Impairment or Disposal of Long-Lived Assets. A long lived asset used in research and development was impaired for \$22,378 as of December 31, 2008.

Income Taxes

The Company accounts for income taxes in accordance with SFAS No. 109, Accounting for Income Taxes, which requires recognition of deferred tax liabilities and assets for the expected future tax consequences of events that have been included in the financial statements or tax returns. Under this method, deferred tax liabilities and assets are determined based on the difference between the financial statement and tax bases of assets and liabilities using tax rates in effect for the year in which the differences are expected to reverse.

In accordance with FIN 48 we recognize the benefits of a tax position if that position is more likely than not of being sustained on audit, based on the technical merit of the position. Management believes it be more likely than not that the Company can sustain management's tax positions on audit.

Use of Estimates

The preparation of financial statements in conformity with generally accepted accounting principles requires management to make estimates and assumptions that affect the reported amounts of assets and liabilities and disclosure of contingent assets and liabilities at the date of the financial statements and the reported amounts of revenue and expenses during the reporting periods. Actual results could differ from those estimates.

Fair Value of Financial Instruments

The carrying amount reported in the balance sheets for cash and cash equivalents, accounts receivable, accounts payable and accrued liabilities approximate their fair value due to the immediate or short-term maturity of such instruments.

2. Accounting Policies (Continued)

Earnings Per Share Data

The Company follows the provisions of SFAS No. 128 Earnings Per Share, which requires the Company to present its basic earnings per share and diluted earnings per share, and certain other earnings per share disclosures for each year presented. Basic earnings per share is computed by dividing income available to common shareholders by the weighted average number of common shares outstanding. The computation of diluted earnings per share is similar to the computation of basic earnings per share except that the denominator is increased to include the average number of additional common shares that would have been outstanding if the dilutive potential common shares had been issued. In addition, the numerator is adjusted for any changes in income that would result from the assumed conversions of those potential shares.

Basic and diluted EPS computations are as follows:

<i>Years ended December 31,</i>	2008	2007
Net income available to common shareholders	\$ 361,283	\$ 1,287,063
Weighted average common shares outstanding	2,709,382	2,710,403
Basic EPS	\$ 0.13	\$ 0.47
Diluted EPS:		
Net income available to common shareholders	\$ 361,283	\$ 1,287,063
Weighted average common shares outstanding, basic	2,709,382	2,710,403
Assumed conversion of net common shares issuable under stock option plans	1,638	49,903
Weighted average common and common equivalent shares outstanding, diluted	2,711,020	2,760,306
Diluted EPS	\$ 0.13	\$ 0.47

Stock-Based Compensation

The Company accounts for share based compensation under the provisions of SFAS No. 123(R), Share-Based Payment, which establishes accounting for equity instruments exchanged for employee services. Under SFAS No. 123(R), share-based compensation cost is measured at the grant date, based on the fair value of the award, and is recognized as an expense over the employee's requisite service period (generally the vesting period of the equity grant).

Comprehensive Income

The Company follows the provisions of SFAS No. 130, Reporting Comprehensive Income, which establishes standards for reporting and display of comprehensive income, its components, and accumulated balances. Comprehensive income is defined to include all changes in equity except those resulting from investments by owners and distributions to owners. The Company did not have any components of comprehensive income, exclusive of net income, for the years ended December 31, 2008 and 2007.

Preferred Stock

The Company has 2,000,000 shares of \$1 par value preferred stock authorized. No shares have been issued.

Shipping and Handling Costs

Shipping and handling costs are classified as a cost of sales in the consolidated statements of income. The custom manufacturing divisions as a normal course of business charge their customer base for shipping and handling, and therefore classify the amounts billed as revenue in the consolidated statements of income.

2. Accounting Policies (Continued)

Industry Segments

The Company follows the provisions of SFAS No. 131, Disclosure about Segments of an Enterprise and Related Information, which requires reporting of selected information about operating segments in interim and annual financial statements issued to the public. It also establishes standards for disclosures regarding products and services, geographic areas, and major customers. SFAS No. 131 defines operating segments as components of an enterprise about which separate financial information is available that is evaluated regularly by the chief operating decision maker in deciding how to allocate resources and in assessing performance.

Research and Development

Research and development expenses include costs directly attributable to the conduct of research and development programs primarily related to the development of our software products and improving the efficiency and capabilities of our manufacturing processes. Such costs include salaries, payroll taxes, employee benefit costs, materials, supplies, depreciation on research equipment, and services provided by outside contractors. All costs associated with research and development are expensed as incurred.

Business Combinations (Leominster Tool Co., Inc.)

On December 27, 2006, Micron completed the purchase of substantially all of the operating assets of privately-held Leominster Tool Co., Inc. ("LTD") of Leominster, Massachusetts. Micron paid LTD approximately \$380,000 in cash, \$120,000 in ART common stock, and recorded a note payable of approximately \$200,000 payable in monthly installments of \$6,290 including interest of 8.25% through December 2009. Micron funded the cash portion of the purchase price out of working capital. At closing, 4,486 treasury shares were issued to cover the \$120,000 stock payment. The purchase price has been allocated to net assets acquired based on their estimated fair values. Currently, it is a division of the Company's wholly owned subsidiary Micron. This note was paid in full during the first three months of 2008.

Restatement Related to Deferred Income Taxes

In 2008, the Company determined that there had been an understatement of the non-current deferred tax liability and an overstatement of the prepaid income taxes in prior periods.

During 2006, an error in the number of periods that the net operating losses could be carried forward was identified and amended returns for the periods ended December 31, 2005 and 2006 were filed. These amended returns resulted in tax refunds of \$147,609 which were collected in 2008. In addition, Federal and State research and development tax credits totaling related to 2003 and 2004 were filed through amendment, and refunded in the periods ended December 31, 2007 and 2008. The cumulative effect of the adjustment on the company's balance sheet as of December 31, 2007 was a \$114,700 reduction in retained earnings, a \$97,200 decrease in prepaid taxes and a \$17,500 increase in non-current deferred tax liability. The adjustment did not have any impact on the company's cash flow statements for any period.

Prior to the year ended December 31, 2003, the company's deferred tax assets, including its NOLs, had been fully offset by a valuation allowance until the year ended December 31, 2004 when the valuation allowance was reversed. As a result, the NOL understatement did not have any impact on the company's income statements or balance sheets for periods prior to 2004 due to the deferred tax asset valuation allowance.

Based on the materiality guidelines contained in SEC Staff Accounting Bulletin No. 99, "Materiality", and SEC Staff Accounting Bulletin No. 108, "Considering the Effects of Prior Year Misstatements in Current Year Financial Statements" (SAB 108), the Company determined that the overall variance between the actual calculations and original estimates was not material in any individual period subsequent to and including the year ended December 31, 2004. However, the Company believes that these adjustments have accumulated to a material amount as of December 31, 2008. In accordance with SAB 108, the Company will not amend its previously filed

affected Annual Reports on Form 10-K because the adjustments are not material to the individual prior years.

The following table shows the restated line items in the accompanying balance sheet as of December 31, 2007 that were impacted by the deferred income tax adjustment:

	Previously Reported	Adjustment	As Restated
Deposits, prepaid expenses and other current assets	\$ 926,970	\$ (97,200)	\$ 829,770
Total current assets	8,418,392	(97,200)	8,321,192
Total assets	17,839,883	(97,200)	17,742,683
Long term deferred tax liability.....	139,000	17,500	156,500
Total long term liabilities	139,000	17,500	156,500
Total liabilities	1,994,345	17,500	2,011,845
Retained earnings.....	8,989,513	(114,700)	8,874,813
Total stockholders' equity	15,845,538	(114,700)	15,730,838

Recent Accounting Pronouncements

In September 2006, the FASB issued SFAS No. 157, "*Fair Value Measurements*". SFAS No. 157 prescribes a single definition of fair value as the price that would be received to sell an asset or paid to transfer a liability in an orderly transaction between market participants at the measurement date. The Company does not believe the adoption of SFAS No. 157 will have a material impact on its financial condition or results of operations. SFAS No. 157 was effective for the Company's interim reporting period beginning January 1, 2008.

In February 2007, the FASB issued SFAS No. 159, "*The Fair Value Option for Financial Assets and Financial Liabilities Including an Amendment of FASB Statement No. 115*". SFAS No. 159 permits an entity to elect fair value as the initial and subsequent measurement attribute for many financial assets and liabilities. Entities electing the fair value option would be required to recognize changes in fair value in earnings. Entities electing the fair value option would also be required to distinguish, on the face of the statement of financial position, the fair value of assets and liabilities for which the fair value option has been elected and similar assets and liabilities measured using another measurement attribute. The Company does not believe the adoption of SFAS No. 159 will have a material impact on its financial condition or results of operations. SFAS No. 159 was effective for the Company's interim reporting period beginning January 1, 2008.

In December 2007, the SEC issued SAB No. 110. SAB 110 allows for the continued use of a "simplified" method, as discussed in SAB No. 107, in developing an estimate of expected term of "plain vanilla" share options in accordance with SFAS 123 (revised 2004). Originally the staff stated in SAB 107 that it would not expect a company to use the simplified method for share option grants after

2. Accounting Policies (Continued)

Recent accounting pronouncements (Continued)

December 31, 2007. Accordingly, the staff will continue to accept, under certain circumstances, the use of the simplified method beyond December 31, 2007. The Company will continue the use of the simplified method for determining the value of options granted as allowed by SAB 110.

In December 2007, the FASB issued SFAS No. 141(R), "Business Combinations". SFAS No. 141(R) establishes principles and requirements for how the acquirer of a business recognizes and measures in its financial statements the identifiable assets acquired, the liabilities assumed, and any non-controlling interest in the acquiree. SFAS No. 141(R) also provides guidance for recognizing and measuring the goodwill acquired in the business combination and determines what information to disclose to enable users of the financial statements to evaluate the nature and financial effects of the business combination. The provisions of SFAS No. 141(R) are applicable to business combinations consummated on or after December 15, 2008 with early adoption prohibited.

In December 2007, the FASB issued SFAS No. 160, "Non-controlling Interests in Consolidated Financial Statements - an amendment of ARB No. 51". SFAS No. 160 establishes accounting and reporting standards for the noncontrolling interest in a subsidiary for the deconsolidation of a subsidiary. SFAS No. 160 is effective for financial statements issued for fiscal years beginning after December 15, 2008, and interim statements within those fiscal years. The Company does not currently have any noncontrolling interests.

3. Inventories

Inventories consist of the following:

<i>December 31,</i>	2008	2007
Raw materials	\$ 1,099,876	\$ 872,758
Work-in-process	773,245	538,309
Finished goods	1,854,371	1,590,453
Total	\$ 3,727,492	\$ 3,001,520

4. Property, Plant and Equipment, Net

Property, plant and equipment consist of the following:

<i>December 31,</i>	Asset Lives	2008	2007
Machinery and equipment	5 to 15 years	\$ 10,532,555	\$ 10,049,906
Equipment held for lease	10 years	69,400	166,003
Building and improvements	20 years	4,038,610	3,667,011
Vehicles	3 to 5 years	158,908	158,908
Furniture, fixtures, computers and software	3 to 5 years	1,319,551	1,163,380
Land		202,492	202,492
Construction in progress		94,829	75,445
Total property, plant and equipment		16,416,345	15,483,145
Less: accumulated depreciation		(9,111,067)	(7,872,887)
Property, plant and equipment, net		\$ 7,305,278	\$ 7,610,258

The Company leases attaching machines to customers under operating leases for periods of up to one year with renewable terms. The cost of the leased equipment is depreciated on a straight-line basis over ten years. Accumulated depreciation on leased equipment was \$142,950 at December 31, 2008 and 2007. The Company sold two leased machines to its customers in 2008 and none in 2007.

5. Debt

The Company has a note payable resulting from the acquisition of Leominster Tool Co. Inc. of approximately \$200,000 with a balance of \$0 and \$134,083 at December 31, 2008 and 2007, respectively. This note was paid in full during the first three months of 2008.

5. Debt (Continued)

The Company has a one year term note secured by equipment for a maximum of \$813,000. The loan was drawn down by \$383,000 for equipment delivered and installed in October. A second payment of \$383,000 was made in January 2008 for this equipment. In the third quarter of 2008 the equipment note was extended for one year with a decrease in the fixed rate from 6.75% to 6.5% per annum. The equipment note is amortized over 6 years with a balloon payment for the remaining balance at September 15, 2009. The balance of this note was \$ 638,091 at December 31, 2008.

The Company has an unsecured \$1,000,000 renewable credit facility which provides for borrowings up to 80% of eligible accounts receivable plus 50% of raw material and finished goods inventories up to a \$300,000 maximum. This facility has no borrowing base charge. There are no outstanding borrowings on the line of credit at December 31, 2008 and 2007.

The agreement contains covenants that apply upon drawing on the line. The covenants relate to various matters including notice prior to executing further borrowings and security interests, merger or consolidation, acquisitions, guarantees, sales of assets other than in the normal course of business, leasing, changes in ownership and payment of dividends.

6. Income Taxes

The income tax provision consists of the following:

<i>Years Ended December 31,</i>	2008	2007
Current:		
Federal	\$ 73,400	\$ 220,000
State	4,000	50,000
	<u>77,400</u>	<u>270,000</u>
Deferred:		
Federal	171,000	189,000
State	13,000	31,000
	<u>184,000</u>	<u>220,000</u>
Total income tax provision	\$ 261,400	\$ 490,000

The components of deferred income taxes are as follows:

<i>December 31,</i>	2008	2007 <i>as restated</i>
Deferred income taxes:		
Inventories	\$ 7,000	\$ 7,000
Other current	14,000	28,000
Total current deferred tax assets	<u>21,000</u>	<u>35,000</u>
Property, plant and equipment	(345,500)	(204,500)
Patents and intangibles	30,000	59,000
Total long term deferred tax liability	<u>(315,500)</u>	<u>(145,500)</u>
Deferred income taxes, net	<u>\$ (294,500)</u>	<u>\$(110,500)</u>

The Company files a consolidated federal income tax return. The actual income tax provision differs from the federal statutory income tax rate (34%) as follows:

<i>Years Ended December 31,</i>	2008	2007
Tax provision computed at statutory rate	\$ 212,000	\$ 604,000
Increases (reductions) due to:		
State income taxes, net of federal benefit	39,000	111,000
Permanent differences	28,000	-
Tax credits (Federal & State)	(68,400)	(213,000)
Other	50,800	(12,000)
Income tax expense	\$ 261,400	\$ 490,000

7. Employee Benefit Plans

The Company sponsors an Employee Savings and Investment Plan under Section 401(k) of the Internal Revenue Code covering all eligible employees of the Company. Employees can contribute up to 90% of their eligible compensation to the maximum allowable by the IRS. The Company's matching contributions are at the discretion of the Company. The Company's matching contributions in 2008 and 2007 were \$30,747 and \$28,853, respectively.

On December 14, 2007, the Board of Directors, after a recommendation from management and approval by the Compensation Committee, granted 107,500 incentive stock options to vest over five years with an effective grant date of January 2, 2008 priced at the average closing price for the prior ten trading days. Forty percent of the options were granted to non-executive management. These options were granted from the shareholder approved 2001 stock option plan described in Note 10.

On April 28, 2005, the Company's Board of Directors adopted the 2005 Stock Award Plan. The Board's objective in adopting the Plan, based on the recommendation of management and approved by the Compensation Committee, was to assist the Company in attracting and retaining the services of certain employees, directors, and consultants deemed to be key and to secure the benefits of the incentive inherent in ownership of the Company's securities. An aggregate of 100,000 shares were available for issuance to employees, directors, and consultants. No awards have been granted under the Stock Award Plan.

8. Commitments and Contingencies

Legal Matters

The Company is from time to time subject to legal proceedings, threats of legal action and claims which arise in the ordinary course of our business. Management believes the resolution of these matters will not have a material adverse effect on our results of operations or financial condition.

Environmental Groundwater

Like many industrial processes, the Micron manufacturing process utilizes hazardous and non-hazardous chemicals, the treatment and disposal of which are subject to federal and state regulation. Since its inception, Micron has expended significant funds to train its personnel, install waste treatment and recovery equipment and retain an independent environmental consulting firm to constantly review, monitor and upgrade its air and waste water treatment activities. As a result, Micron believes that the operations of its manufacturing facility are in compliance with currently applicable safety, health and environmental laws and regulations.

Based on the Company's analyses and subject to the difficulty in estimating these future costs, the Company does not expect future costs in connection with environmental matters to have a material adverse effect on its financial condition, result of operations or liquidity.

Employment Agreements

The Company has employment agreements with two executives extending through October 5, 2011 and January 1, 2012. The agreements provide for a base compensation and certain other benefits. The agreements also contain other terms and conditions of employment, including termination payments under certain circumstances.

Operating Leases

The Company leases vehicles and equipment under non-cancelable lease arrangements. Lease expense under all operating leases was approximately \$10,700 and \$12,400 in 2008 and 2007, respectively.

Future minimum operating lease payments as of December 31, 2008 are approximately as follows:

<i>Year</i>	<i>Amount</i>
2009	8,100
2010	6,700
Total	\$ 14,800

9. Supplemental Cash Flow Information

Cash paid for income taxes and interest for the years ended December 31 are as follows:

	2008	2007
Income taxes	\$ 109,000	\$ 458,000
Interest	47,826	21,000

At December 31, 2008 the Company has \$1,118 of dividends payable.

In 2007, an additional capital expenditure of \$765,000 made use of a term note and did not require a cash outlay from the Company.

10. Stock Options

The Company accounts for its share based payments under the provisions of SFAS No. 123(R), *Share Based Payment*, which establishes accounting for equity instruments exchanged for employee services. Under SFAS No. 123(R), share-based compensation cost is measured at the grant date, based on the fair value of the award, and is recognized as an expense over the employee's requisite service period (generally the vesting period of the equity grant).

For the year ended December 31, 2008 and 2007, share-based compensation included in general and administrative expenses amounted to \$100,229 and \$45,641, respectively.

The fair value of each stock option granted is estimated on the date of grant using the Black-Scholes option-pricing model. Key assumptions used to estimate the fair value of the stock options include the exercise price of the award, the expected option term, the expected volatility of the Company's stock over the option's expected term, the risk free interest rate over the option's expected term, and the Company's expected annual dividend yield. The Company believes that the valuation technique and the approach utilized to develop the underlying assumptions are appropriate in calculating the fair values of the Company's stock options for the year ended December 31, 2008 and 2007. Estimates of fair values are not intended to predict actual future events or the value ultimately realized by persons who receive equity awards.

The fair value of each option grant in 2008 and 2007 were estimated on the grant date using the Black-Scholes option pricing model with the following assumptions:

	<u>2008</u>	<u>2007</u>
Expected option term ⁽¹⁾	4.5 years	6 years
Expected volatility factor ⁽²⁾	41%	43%
Risk-free interest rate ⁽³⁾	3.3%	5.5%
Expected annual dividend yield	0.0%	0.44%

- (1) The option life was determined using the simplified method for estimated expected option life, which qualifies as "plain-vanilla" options.
- (2) The stock volatility for each grant is determined based on the review of the experience of the weighted average of historical daily price changes of the Company's common stock over the most recent year.
- (3) The risk-free interest rate for periods equal to the expected term of the share option is based on the U.S. Treasury yield curve in effect at the time of grant.

10. Stock Options (Continued)

Share-Based Incentive Plan

At December 31, 2008, the Company had one stock option plan that includes both incentive and non-qualified stock options to be granted to certain eligible employees, non-employee directors, or consultants. The maximum number of shares reserved for issuance is 400,000 shares. The options granted have six-year contractual terms and either vest immediately or vest annually over a five-year term.

At December 31, 2008, there were 139,000 shares available for future grants under the above stock option plan.

The following table sets forth the stock option transactions for the year ended December 31, 2008:

	Number of shares	Weighted average Exercise Price	Weighted average remaining contractual term	Aggregate Intrinsic Value
Outstanding at December 31, 2006	113,000	\$ 8.98	4.5 years	\$ 1,412,490
Granted	20,000	18.60		
Exercised	(6,000)	9.86		
Cancelled/expired	-	-		
Outstanding at December 31, 2007	127,000	\$ 10.45	3.8 years	\$ 50,750
Granted	107,500	\$ 7.15		
Exercised	-	-		
Cancelled/expired	(26,500)	\$ 10.39		
Outstanding at December 31, 2008	208,000	\$ 10.45	3.7 years	\$ -
Exercisable at end of year	97,000	\$ 8.85	2.4 years	\$ -

The weighted average fair value of stock options granted during 2008 and 2007 was \$2.73 and \$8.83, respectively.

During the year ended December 31, 2008, no options were exercised. At December 31, 2008, the intrinsic value of the exercisable options is \$0.

During the year ended December 31, 2007, the total intrinsic value of options exercised (the difference between the market price and the price paid by the employee to exercise the options) was \$98,950 and the total amount of cash received from the exercise of these options was \$59,160. The actual tax benefit realized for the tax deductions from options exercised totaled \$33,549. At December 31, 2007, the intrinsic value of the exercisable options is \$40,600.

The following table sets forth the status of the Company's non-vested options for the year ended December 31, 2008:

	Number of shares	Weighted average Fair Value
Non-vested at December 31, 2007	33,000	\$ 7.15
Granted	107,500	2.74
Vested (with an intrinsic value of \$0)	(9,000)	3.95
Cancelled/expired	(20,500)	4.76
Non-vested at December 31, 2008	111,000	\$ 3.46

10. Stock Options (Continued)

The following table presents the average price and contractual life information about options outstanding and exercisable at December 31, 2007:

Exercise Price	Number of Outstanding Shares	Weighted Average Remaining Contractual Life (years)	Options Currently Exercisable
\$ 4.85	25,000	0.58	25,000
7.15	97,000	5.00	-
9.86	66,000	2.97	66,000
12.42	10,000	3.59	4,000
23.10	10,000	4.18	2,000

As of December 31, 2008, there was \$297,169 of unrecognized compensation cost related to non-vested share based compensation arrangements granted under the stock option plan. This cost is expected to be recognized over a weighted average period of 5.1 years.

As of December 31, 2007, there was \$184,291 of unrecognized compensation cost related to non-vested share based compensation arrangements granted under the stock option plan. This cost is expected to be recognized over a weighted average period of 5.1 years.

11. Industry and Geographic Segments

The Company's operations are classified into two business segments: medical electrode components and plastic molding, and computerized medical instruments.

The following table shows sales, operating income (loss) and other financial information by industry segment as of and for the years ended December 31, 2008 and 2007:

<i>Year ended December 31, 2008</i>	Medical Electrode Components and Plastic Molding	Computerized Medical Instruments	Corporate	Consolidated
Sales	\$ 22,482,219	\$ -	\$ -	\$ 22,482,219
Operating income (loss)	\$ 2,185,345	\$ (375,832)	\$ (1,169,964)	\$ 639,549
Capital Expenditures	\$ 991,646	\$ -	\$ 24,056	\$ 1,015,702
Depreciation and Amortization	\$ 1,316,097	\$ -	\$ 83,057	\$ 1,399,154
Total Assets at December 31, 2008	\$ 15,590,769	\$ 72,217	\$ 2,825,581	\$ 18,488,567
<i>Year ended December 31, 2007</i>	Medical Electrode Components and Plastic Molding	Computerized Medical Instruments	Corporate	Consolidated
Sales	\$ 19,487,111	\$ 651	\$ -	\$ 19,487,762
Operating income (loss)	\$ 2,820,492	\$ (73,959)	\$ (975,993)	\$ 1,770,540
Capital Expenditures	\$ 2,242,530	\$ -	\$ 395,105	\$ 2,637,635
Depreciation and Amortization	\$ 1,128,708	\$ -	\$ 19,755	\$ 1,148,463
Total Assets at December 31, 2007 as restated	\$ 15,044,362	\$ 338,052	\$ 2,349,269	\$ 17,731,683

11. Industry and Geographic Segments (Continued)

The following table sets forth the geographic distribution of the Company's net sales:

	2008	2007
United States	\$ 13,290,098	\$ 10,824,992
Canada	5,118,913	5,426,042
Europe	3,091,326	2,496,012
Pacific Rim	426,764	335,592
Other	555,118	405,124
Net Sales	\$ 22,482,219	\$ 19,487,762

The following table sets forth the percentage of net sales to significant customers of the medical electrode and injection molded component segment in relation to total segment sales:

Customers	2008	2007
A	27%	27%
B	12%	25%
C	17%	

12. Quarterly Financial Data

<i>(unaudited)</i>	First Quarter	Second Quarter	Third Quarter	Fourth Quarter
<u>2008</u>				
Net Sales	\$ 5,459,742	\$ 6,426,120	\$ 5,838,390	\$ 4,757,967
Gross Profit	1,111,438	1,346,471	841,560	978,224
Net Income	149,372	134,119	68,139	9,753
Basic Earnings per share	0.06	0.05	0.03	0.00
Diluted Earnings per share	0.05	0.05	0.03	0.00
<u>2007</u>				
Net Sales	\$ 5,009,276	\$ 5,400,218	\$ 4,457,688	\$ 4,620,580
Gross Profit	1,062,929	1,269,025	1,254,395	1,192,378
Net Income	233,780	446,400	420,542	186,341
Basic Earnings per share	0.09	0.16	0.16	0.07
Diluted Earnings per share	0.08	0.16	0.15	0.07

EXHIBIT INDEX

Exhibit Number	Description of Exhibit	Page
3.0	Articles of Incorporation	(a)
3.1	Amended and Restated By-laws	(c)
4.0	Form of Certificate evidencing shares of the Company's Common Stock.....	(a)
4.6*	2001 Stock Option Plan.....	(b)
4.8*	2005 Stock Award Plan.....	(e)
10.43*	Employment agreement between James E. Rouse and the Company dated December 26 th , 2006.	(f)
10.44*	Employment agreement between David A. Garrison and the Company dated January 1, 2007.....	(f)
21.0	Subsidiaries.....	(g)
23.1	Consent of CCR LLP	X-1
31.1	Certification of the CEO pursuant to Rule 13a-14(a) or Rule 15(d)-14(a)	X-2
31.2	Certification of the CFO pursuant to Rule 13a-14(a) or Rule 15(d)-14(a).....	X-3
32.1	Certification pursuant to 18 U.S.C. §1350 as adopted pursuant to Section 906 of the Sarbanes- Oxley Act of 2002.....	X-4
32.2	Certification pursuant to 18 U.S.C. §1350 as adopted pursuant to Section 906 of the Sarbanes- Oxley Act of 2002.....	X-5

* Indicates a management contract or compensatory plan required to be filed as an exhibit.

- (a) Incorporated by reference to the Company's Registration Statement on Form S-18 as filed with the Commission in April 1988, Registration Statement No. 33-20945-FW.
- (b) Incorporated by reference to the Company's Form 10-K for fiscal year ended December 31, 2001 as filed with the Commission in March 2002.
- (c) Incorporated by reference to the Company's Current Report on Form 8-K as filed with the Commission in December 2007.
- (d) Incorporated by reference to the Company's Form 10-KSB for fiscal year ended December 31, 2002 as filed with the Commission in March 2003.
- (e) Incorporated by reference to the Company's Registration Statement on Form S-8 as filed with the Commission in December 2005, Registration Statement No. 333-130678.
- (f) Incorporated by reference to the Company's Form 10-KSB for fiscal year ended December 31, 2006, as filed with the Commission in March 2007.
- (g) Incorporated by reference to the Company's Form 10-K for the fiscal year ended December 31, 2007 as filed with the Commission in March 2008.